

Our associates will ensure the tool works properly before you leave the store. If you experience issues with the tool while completing your project, simply bring it back to the Tool Rental Center to get a replacement. If you purchase Damage Protection at the time of your rental, you are not responsible for repair costs for tools that break due to normal use.



IMPORTANT
Read Before Using

IMPORTANT
Lire avant usage

IMPORTANTE
Leer antes de usar



Operating / Safety Instructions Saw and Stand

4100XC

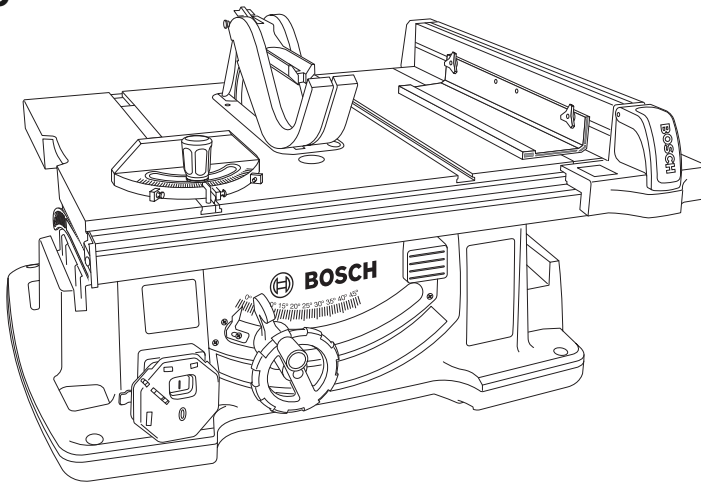

BOSCH

Call Toll Free for Consumer Information and Service Locations

Pour obtenir des informations et les adresses de nos centres de service après-vente, appelez ce numéro gratuit

Llame gratis para obtener información para el consumidor y ubicaciones de servicio

1-877-BOSCH99 (1-877-267-2499) www.boschtools.com

For English Version
See page 2

Version française
Voir page 49

Versión en español
Ver la página 102

Safety Symbols

The definitions below describe the level of severity for each signal word. Please read the manual and pay attention to these symbols.





	This is the safety alert symbol. It is used to alert you to potential personal injury hazards. Obey all safety messages that follow this symbol to avoid possible injury or death.
	DANGER indicates a hazardous situation which, if not avoided, will result in death or serious injury.
	WARNING indicates a hazardous situation which, if not avoided, could result in death or serious injury.
	CAUTION indicates a hazardous situation which, if not avoided, could result in minor or moderate injury.

Table of Contents

Safety Symbols	2	Rip Fence and Thin Workpiece	
General Power Tool Safety Warnings	3	Fence Storage22
1. Work area safety	3	Smart Guard System Storage22
2. Electrical safety	3	Mounting The Table Saw23
3. Personal safety	4	Adjustments23
4. Power tool use and care	4	Adjusting Blade Parallel to the	
5. Service	5	Miter Gauge Slots23
Safety Instructions for Table Saws	5	Miter Gauge Adjustment24
1. Guarding related warnings	5	Rip Fence Adjustments25
2. Cutting procedures warnings	5	Aligning Rip Fence25
3. Kickback causes and related warnings ..	6	Rip Fence Pointer Adjustment25
4. Table saw operating procedure warnings ..	7	To Set The Rip Fence Pointer:25
Additional Safety Rules	8	Table Pointer Adjustment26
Intended Use	8	Riving Knife Alignment26
Specifications	9	Checking Riving Knife Alignment26
Double Insulated Tools	9	Adjusting Riving Knife27
Extension Cords	9	Adjusting the Table Insert27
Symbols	10	Adjusting 0 and 45 Degree Positive Stops ..	.28
Getting To Know Your Table Saw	12	Adjusting 0 Degree Positive Stop:28
Glossary of Terms	14	Adjusting 45 Degree Positive Stop:28
Unpacking And Checking Contents	15	Basic Table Saw Operation29
Tools Needed For Assembly	16	Power Switch29
Assembly	17	Using the Smart Guard System29
Attaching Bottom Screen	17	Riving Knife / Splitter30
Attaching the Smart Guard System	17	Main Barrier Guard30
Positioning The Riving Knife	17	Anti-Kickback Device30
Attaching The Guard Assembly	18	Making Work Helpers30
Attaching The Anti-Kickback Device	18	Making Push Stick and Push Block31
Selecting and Changing the Blade	19	Making auxiliary fence31
Using the Correct Blade	19	Making a Featherboard31
Changing the Blade	20	Making The Facing Block32
Attaching Rip Fence	20	Making Rip Fence Auxiliary Facing32
Attaching Thin Workpiece Fence	21	Using the Push Stick, Push Block,	
Storage, Transportation, and Mounting ...	21	and Auxiliary Fence33
Miter Gauge and Push stick Storage	21	Push Stick33

Table of Contents

Making Miter Gauge Auxiliary Facing33	Bevel Crosscutting40
Push Block34	Compound Miter Cutting40
Auxiliary and Thin Workpiece Fence34	Non-Thru Cutting41
Blade Bevel Control35	Rabbeting41
Extending Table Extension35	Dado Cutting42
Pre-Cut Locator35	Installing a Dado Set42
Using The Rip Fence36	Using Stacked Dado Sets42
Ripping36	Returning Saw to Normal Thru-Cutting . .	.44
Bevel Ripping36	Adjustable or Wobble Dado Sets44
Using The Rip Fence Pointer		Installing a Molding Head Set44
When Table Is Not Extended37	Returning Saw to Normal Thru-Cutting . .	.45
Using The Table Pointer When		Special Cutting Techniques45
Table Is Extended37	Maintaining Your Table Saw46
Using The Miter Gauge38	General Maintenance46
Adjusting The Miter Angle:38	Lubrication46
Crosscutting38	Attachments47
Repetitive Crosscutting39	Troubleshooting48
Making The Repetitive Crosscut39		
Miter Cutting40		

General Power Tool Safety Warnings

⚠ WARNING Read all safety warnings, instructions, illustrations and specifications provided with this power tool. Failure to follow all instructions listed below may result in electric shock, fire and/or serious injury.

SAVE ALL WARNINGS AND INSTRUCTIONS FOR FUTURE REFERENCE

The term “power tool” in the warnings refers to your mains-operated (corded) power tool or battery-operated (cordless) power tool.

1. Work area safety

- Keep work area clean and well lit.** Cluttered or dark areas invite accidents.
- Do not operate power tools in explosive atmospheres, such as in the presence of flammable liquids, gases or dust.** Power tools create sparks which may ignite the dust or fumes.
- Keep children and bystanders away while operating a power tool.** Distractions can cause you to lose control.
- Make workshop child-proof with padlocks and/or master switches.**

2. Electrical safety

- Power tool plugs must match the outlet. Never modify the plug in any way. Do not use any adapter plugs with earthed (grounded) power tools.** Unmodified plugs and matching outlets will reduce risk of electric shock.
- Avoid body contact with earthed or grounded surfaces, such as pipes, radiators, ranges and**

refrigerators. There is an increased risk of electric shock if your body is earthed or grounded.

- Do not expose power tools to rain or wet conditions.** Water entering a power tool will increase the risk of electric shock.
- Do not abuse the cord. Never use the cord for carrying, pulling or unplugging the power tool. Keep cord away from heat, oil, sharp edges or moving parts.** Damaged or entangled cords increase the risk of electric shock.
- When operating a power tool outdoors, use an extension cord suitable for outdoor use.** Use of a cord suitable for outdoor use reduces the risk of electric shock.
- If operating a power tool in a damp location is unavoidable, use a Ground Fault Circuit Interrupter (GFCI) protected supply.** Use of an GFCI reduces the risk of electric shock.
- Before connecting the tool to a power source (receptacle, outlet, etc.), be sure voltage supplied is the same as that specified on the nameplate of the tool.** A power source with voltage greater than that specified for the tool

General Power Tool Safety Warnings

can result in serious injury to the user — as well as damage to the tool. If in doubt, DO NOT PLUG IN THE TOOL. Using a power source with voltage less than the nameplate rating is harmful to the motor.

3. Personal safety

- a. **Stay alert, watch what you are doing and use common sense when operating a power tool. Do not use a power tool while you are tired or under the influence of drugs, alcohol or medication.** A moment of inattention while operating power tools may result in serious personal injury.
- b. **Use personal protective equipment. Always wear eye protection.** Protective equipment such as dust mask, non-skid safety shoes, hard hat, or hearing protection used for appropriate conditions will reduce personal injuries.
- c. **Prevent unintentional starting. Ensure the switch is in the off-position before connecting to power source and / or battery pack, picking up or carrying the tool.** Carrying power tools with your finger on the switch or energizing power tools that have the switch on invites accidents.
- d. **Remove any adjusting key or wrench before turning the power tool on.** A wrench or a key left attached to a rotating part of the power tool may result in personal injury.
- e. **Do not overreach. Keep proper footing and balance at all times.** This enables better control of the power tool in unexpected situations.
- f. **Dress properly. Do not wear loose clothing or jewelry. Keep your hair, clothing and gloves away from moving parts.** Loose clothes, jewelry or long hair can be caught in moving parts.
- g. **If devices are provided for the connection of dust extraction and collection facilities, ensure these are connected and properly used.** Use of dust collection can reduce dust-related hazards.
- h. **Do not let familiarity gained from frequent use of tools allow you to become complacent and ignore tool safety principles.** A careless action can cause severe injury within a fraction of a second.
- b. **Do not use the power tool if the switch does not turn it on and off.** Any power tool that cannot be controlled with the switch is dangerous and must be repaired.
- c. **Disconnect the plug from the power source and/or remove the battery pack, if detachable, from the power tool before making any adjustments, changing accessories, or storing power tools.** Such preventive safety measures reduce the risk of starting the power tool accidentally.
- d. **Store idle power tools out of the reach of children and do not allow persons unfamiliar with the power tool or these instructions to operate the power tool.** Power tools are dangerous in the hands of untrained users.
- e. **Maintain power tools and accessories. Check for misalignment or binding of moving parts, breakage of parts and any other condition that may affect the power tool's operation. If damaged, have the power tool repaired before use.** Many accidents are caused by poorly maintained power tools.
- f. **Keep cutting tools sharp and clean.** Properly maintained cutting tools with sharp cutting edges are less likely to bind and are easier to control.
- g. **Use the power tool, accessories and tool bits etc. in accordance with these instructions, taking into account the working conditions and the work to be performed.** Use of the power tool for operations different from those intended could result in a hazardous situation.
- h. **Keep handles and grasping surfaces dry, clean and free from oil and grease.** Slippery handles and grasping surfaces do not allow for safe handling and control of the tool in unexpected situations.
- i. **Do not alter or misuse tool.** These tools are precision built. Any alteration or modification not specified is misuse and may result in dangerous conditions.
- j. **Do not operate this table saw until it is completely assembled and installed according to the instructions and until you have read and understood the following:**
 1. General Power Tool Safety Warnings3-5
 2. Safety Instructions for Table Saws 5-7
 3. Additional Safety Rules8
 4. Intended Use8
 5. Specifications9
 6. Double Insulated Tools9
 7. Getting To Know Your Table Saw . .12-13

4. Power tool use and care

- a. **Do not force the power tool. Use the correct power tool for your application.** The correct power tool will do the job better and safer at the rate for which it was designed.

General Power Tool Safety Warnings

- 8. Unpacking And Checking Contents 15
- 9. Assembly17–21
- 10. Storage, Transportation,
and Mounting21–23
- 12. Adjustments23–28
- 12. Basic Table Saw Operation29–45
- 13. Maintaining Your Table Saw46

5. Service

- a. **Have your power tool serviced by a qualified repair person using only identical replacement parts.** This will ensure that the safety of the power tool is maintained.

Safety Instructions for Table Saws

1. Guarding related warnings

- a. **Keep guards in place. Guards must be in working order and be properly mounted.** A guard that is loose, damaged, or is not functioning correctly must be repaired or replaced.
- b. **Always use saw blade guard, riving knife and anti-kickback device for every through-cutting operation.** For through-cutting operations where the saw blade cuts completely through the thickness of the workpiece, the guard and other safety devices help reduce the risk of injury.
- c. **Immediately reattach the guarding system after completing an operation (such as rabbeting, dadoing or resawing cuts) which requires removal of the guard, riving knife and/or anti-kickback device.** The guard, riving knife, and anti-kickback device help to reduce the risk of injury.
- d. **Make sure the saw blade is not contacting the guard, riving knife or the workpiece before the switch is turned on.** Inadvertent contact of these items with the saw blade could cause a hazardous condition.
- e. **Adjust the riving knife as described in this instruction manual.** Incorrect spacing, positioning and alignment can make the riving knife ineffective in reducing the likelihood of kickback.
- f. **For the riving knife and anti-kickback device to work, they must be engaged in the workpiece.** The riving knife and anti-kickback device are ineffective when cutting workpieces that are too short to be engaged with the riving knife and anti-kickback device. Under these conditions a kickback cannot be prevented by the riving knife and antikickback device.
- g. **Use the appropriate saw blade for the riving knife.** For the riving knife to function properly, the saw blade diameter must match the appropriate riving knife and the body of the saw blade must be thinner than the thickness of the riving knife and the cutting width of the saw

blade must be wider than the thickness of the riving knife.

2. Cutting procedures warnings

- a. ** DANGER** Never place your fingers or hands in the vicinity or in line with the saw blade. A moment of inattention or a slip could direct your hand towards the saw blade and result in serious personal injury.
- b. **Feed the workpiece into the saw blade or cutter only against the direction of rotation.** Feeding the workpiece in the same direction that the saw blade is rotating above the table may result in the workpiece, and your hand, being pulled into the saw blade.
- c. **Never use the miter gauge to feed the workpiece when ripping and do not use the rip fence as a length stop when cross cutting with the miter gauge.** Guiding the workpiece with the rip fence and the miter gauge at the same time increases the likelihood of saw blade binding and kickback.
- d. **When ripping, always apply the workpiece feeding force between the fence and the saw blade. Use a push stick when the distance between the fence and the saw blade is less than 150 mm (6 in.), and use a push block when this distance is less than 50 mm (2 in.).** “Work helping” devices will keep your hand at a safe distance from the saw blade.
- e. **Use only the push stick provided by the manufacturer or constructed in accordance with the instructions.** This push stick provides sufficient distance of the hand from the saw blade.
- f. **Never use a damaged or cut push stick.** A damaged push stick may break causing your hand to slip into the saw blade.
- g. **Do not perform any operation “freehand”. Always use either the rip fence or the miter gauge to position and guide the workpiece.** “Freehand” means using your hands to support

Safety Instructions for Table Saws

or guide the workpiece, in lieu of a rip fence or miter gauge. Freehand sawing leads to misalignment, binding and kickback.

- h. **Never reach around or over a rotating saw blade.** Reaching for a workpiece may lead to accidental contact with the moving saw blade.
- i. **Provide auxiliary workpiece support to the rear and/or sides of the saw table for long and/or wide workpieces to keep them level.** A long and/or wide workpiece has a tendency to pivot on the table's edge, causing loss of control, saw blade binding and kickback.
- j. **Feed workpiece at an even pace. Do not bend or twist the workpiece. If jamming occurs, turn the tool off immediately, unplug the tool then clear the jam.** Jamming the saw blade by the workpiece can cause kickback or stall the motor.
- k. **Do not remove pieces of cut-off material while the saw is running.** The material may become trapped between the rip fence or inside the saw blade guard and the saw blade pulling your fingers into the saw blade. Turn the saw off and wait until the saw blade stops before removing material.
- l. **Use an auxiliary fence in contact with the table top when ripping workpieces less than 2 mm (0.08 in) thick.** A thin workpiece may wedge under the rip fence and create a kickback.

3. Kickback causes and related warnings

Kickback is a sudden reaction of the workpiece due to a pinched, jammed saw blade or misaligned line of cut in the workpiece with respect to the saw blade or when a part of the workpiece binds between the saw blade and the rip fence or other fixed object.

Most frequently during kickback, the workpiece is lifted from the table by the rear portion of the saw blade and is propelled towards the operator. Kickback is the result of saw misuse and/or incorrect operating procedures or conditions and can be avoided by taking proper precautions as given below.

- a. **Never stand directly in line with the saw blade. Always position your body on the same side of the saw blade as the fence.** Kickback may propel the workpiece at high velocity towards anyone standing in front and in line with the saw blade.
- b. **Never reach over or in back of the saw blade to pull or to support the workpiece.** Acciden-

tal contact with the saw blade may occur or kickback may drag your fingers into the saw blade.

- c. **Never hold and press the workpiece that is being cut off against the rotating saw blade.** Pressing the workpiece being cut off against the saw blade will create a binding condition and kickback.
- d. **Align the fence to be parallel with the saw blade.** A misaligned fence will pinch the workpiece against the saw blade and create kickback.
- e. **Use a featherboard to guide the workpiece against the table and fence when making non-through cuts such as rabbeting, dadoing or resawing cuts.** A featherboard helps to control the workpiece in the event of a kickback.
- f. **Use extra caution when making a cut into blind areas of assembled workpieces.** The protruding saw blade may cut objects that can cause kickback.
- g. **Support large panels to minimize the risk of saw blade pinching and kickback.** Large panels tend to sag under their own weight. Support(s) must be placed under all portions of the panel overhanging the table top.
- h. **Use extra caution when cutting a workpiece that is twisted, knotted, warped or does not have a straight edge to guide it with a miter gauge or along the fence.** A warped, knotted, or twisted workpiece is unstable and causes misalignment of the kerf with the saw blade, binding and kickback.
- i. **Never cut more than one workpiece, stacked vertically or horizontally.** The saw blade could pick up one or more pieces and cause kickback.
- j. **When restarting the saw with the saw blade in the workpiece, center the saw blade in the kerf so that the saw teeth are not engaged in the material.** If the saw blade binds, it may lift up the workpiece and cause kickback when the saw is restarted.
- k. **Keep saw blades clean, sharp, and with sufficient set. Never use warped saw blades or saw blades with cracked or broken teeth.** Sharp and properly set saw blades minimize binding, stalling and kickback. Cleaning accumulated sap or plastic from the tips and body of the blade will reduce overheating and binding of the blade. When cutting plastic materials, avoid melting the plastic.
- l. **Do not release the workpiece until you have pushed it all the way past the sawblade.** Failure to do so may cause kickback and personal injury.

Safety Instructions for Table Saws

- m. **Do not confine the cut-off piece when ripping or cross cutting.** Confining the cut-off piece when ripping or cross cutting may cause kickback and personal injury.
- n. **Replace or sharpen the anti-kickback pawls when points become dull.** Sharp anti-kickback pawls minimize kickback.
- o. **Keep sawblade guard, riving knife and anti-kickback pawls in place and operating properly.** The riving knife must be in alignment with the sawblade and the pawls must stop a kickback once it has started. Check their action before ripping. Keeping these parts operating properly minimizes kick-back.

4. Table saw operating procedure warnings

- a. **Turn off the table saw and disconnect the power cord when removing the table insert, changing the saw blade or making adjustments to the riving knife, antikickback device or saw blade guard, and when the machine is left unattended.** Precautionary measures will avoid accidents.
- b. **Never leave the table saw running unattended. Turn it off and don't leave the tool until it comes to a complete stop.** An unattended running saw is an uncontrolled hazard.
- c. **Locate the table saw in a well-lit and level area where you can maintain good footing and balance. It should be installed in an area that provides enough room to easily handle the size of your workpiece.** Cramped, dark areas, and uneven slippery floors invite accidents.
- d. **Frequently clean and remove sawdust from under the saw table and/or the dust collection device.** Accumulated sawdust is combustible and may self-ignite.
- e. **The table saw must be secured.** A table saw that is not properly secured may move or tip over.
- f. **Remove tools, wood scraps, etc. from the table before the table saw is turned on.** Distraction or a potential jam can be dangerous.
- g. **Always use saw blades with correct size and shape (diamond versus round) of arbor holes.** Saw blades that do not match the mounting hardware of the saw will run off-center, causing loss of control.
- h. **Never use damaged or incorrect saw blade mounting means such as flanges, saw blade washers, bolts or nuts.** These mounting means were specially designed for your saw, for safe operation and optimum performance.
- i. **Never stand on the table saw, do not use it as a stepping stool.** Serious injury could occur if the tool is tipped or if the cutting tool is accidentally contacted.
- j. **Make sure that the saw blade is installed to rotate in the proper direction. Do not use grinding wheels, wire brushes, or abrasive wheels on a table saw.** Improper saw blade installation or use of accessories not recommended may cause serious injury.
- k. **Use only accessories that are recommended by the manufacturer for your model.** Accessories that may be suitable for one tool, may become hazardous when used on another tool.
- l. **If you stall or jam the sawblade in the workpiece, turn saw "OFF" and eliminate reason for stalling or jamming before restarting. Remove the workpiece from the sawblade, and replace if it is binding. Check to see if the sawblade is parallel to the table slots or grooves and if the riving knife is in proper alignment with the sawblade.** If ripping at the time, check to see if rip fence is parallel with the sawblade. Readjust as indicated.
- m. **Do not remove small pieces of cut-off material that may become trapped inside the blade guard while the saw is running. Turn saw "OFF" and wait until blade stops.** Removal of such pieces while saw is running could endanger your hands or cause a kickback.
- n. **Crosscutting operations are more conveniently worked and with greater safety if an auxiliary wood facing is attached to the miter gauge.** See page 32.
- o. **Do not use any blade or other cutting tool marked for an operating speed less than 3650 R.P.M.** Using a blade or other cutting tool that is rated less could cause personal injury. Never use a cutting tool larger in diameter than the diameter for which the saw was designed. For greatest safety and efficiency when ripping, use the maximum diameter blade for which the saw is designed, since under these conditions the riving knife is nearest the blade.
- p. **Make sure the table insert is flush or slightly below the table surface on all sides except for rear side. NEVER operate the saw unless the proper insert is installed.** Operation without proper insert can lead to kickback and personal injury.

Additional Safety Rules

Develop a periodic maintenance schedule for your tool. When cleaning a tool be careful not to disassemble any portion of the tool since internal wires may be misplaced or pinched or safety guard return springs may be improperly mounted. Certain cleaning agents such as gasoline, carbon tetrachloride, ammonia, etc. may damage plastic parts.

⚠ WARNING Some dust created by power sanding, sawing, grinding, drilling, and other construction activities contains chemicals known to cause cancer, birth defects or other reproductive harm. Some examples of these chemicals are:

- Lead from lead-based paints,
- Crystalline silica from bricks and cement and other masonry products, and
- Arsenic and chromium from chemically treated lumber.

Your risk from these exposures varies, depending on how often you do this type of work. To reduce your exposure to these chemicals: work in a well ventilated area, and work with approved safety equipment, such as those dust masks that are specially designed to filter out microscopic particles.

THINK SAFETY

SAFETY IS A COMBINATION OF OPERATOR COMMON SENSE AND ALERTNESS AT ALL TIMES WHEN POWER TOOLS ARE BEING USED.

SAVE THESE INSTRUCTIONS

Intended Use

⚠ WARNING Use this table saw only as intended. Unintended use may result in personal injury and property damage.

This table saw is designed for professional rip, cross, miter, bevel and non-thru cut applications in various materials.

Do not use this table saw for cutting metals, such as aluminum or copper, or any masonry or cement materials.

Do not use wobble or adjustable dado sets with this table saw.

Do not perform tapered cuts without a tapered jig accessory.

Specifications

Voltage	120V~ 60Hz
Amperage	15A
No load speed	3650/min (RPM)
Blade diameter	Ø10" (254mm)
Rip cut right - closed	14-1/2" (368 mm)
Rip cut right - extended	30" (760 mm)
Rip cut left	9-1/4" (235 mm)
Depth of cut at 90°	3-1/8" (79 mm)
Depth of cut at 45°	2-1/4" (57mm)
Factory set bevel range	0° / 45°
Bevel range without stops	-2° / 47°
Dado blade diameters	8" (203 mm) and 6" (152 mm)
Maximum dado stack width	13/16" (20.6 mm)

Double Insulated Tools

Double insulation  is a design concept used in electric power tools which eliminates the need for the three wire grounded power cord and grounded power supply system. It is a recognized and approved system by Underwriter's Laboratories, CSA and Federal OSHA authorities.

IMPORTANT: Servicing of a tool with double insulation requires care and knowledge of the system and should be performed only by a qualified service technician.

WHEN SERVICING, USE ONLY IDENTICAL REPLACEMENT PARTS.

POLARIZED PLUGS. To reduce the risk of electrical shock, your tool is equipped with a polarized plug (one blade is wider than the other), this plug will fit in a polarized outlet only one way. If the plug does not fit fully in the outlet, reverse the plug. If it still does not fit, contact a qualified electrician to install the proper outlet. To reduce the risk of electrical shock, do not change the plug in any way.

Extension Cords

Replace damaged cords immediately. Use of damaged cords can shock, burn or electrocute.

If an extension cord is necessary, a cord with adequate size conductors should be used to prevent excessive voltage drop, loss of power or overheating. The table shows the correct size to use, depending on cord length and nameplate amperage rating of tool. If in doubt, use the next heavier gauge. Always use U.L. and CSA listed extension cords.







RECOMMENDED SIZES OF EXTENSION CORDS 120 VOLT ALTERNATING CURRENT TOOLS

Tool's Ampere Rating	Cord Size in A.W.G.				Wire Sizes in mm ²			
	Cord Length in Feet				Cord Length in Meters			
	25	50	100	150	15	30	60	120
3-6	18	16	16	14	0.75	0.75	1.5	2.5
6-8	18	16	14	12	0.75	1.0	2.5	4.0
8-10	18	16	14	12	0.75	1.0	2.5	4.0
10-12	16	16	14	12	1.0	2.5	4.0	-
12-16	14	12	-	-	-	-	-	-

NOTE: The smaller the gauge number, the higher the cord capacity.











Symbols

Important: Some of the following symbols may be used on your tool. Please study them and learn their meaning. Proper interpretation of these symbols will allow you to operate the tool better and safer.

Symbol	Designation / Explanation
V	Volts (voltage)
A	Amperes (current)
Hz	Hertz (frequency, cycles per second)
W	Watt (power)
kg	Kilograms (weight)
min	Minutes (time)
s	Seconds (time)
CFM	Cubic feet per minute [or ft ³ /min] (air flow rate)
∅	Diameter (size of drill bits, grinding wheels, etc.)
n ₀	No load speed (rotational speed at no load)
n	Rated speed (maximum attainable speed)
.../min	Revolutions or reciprocation per minute (revolutions, strokes, surface speed, orbits etc. per minute)
0	Off position (zero speed, zero torque...)
1, 2, 3, ... I, II, III,	Selector settings (speed, torque or position settings. Higher number means greater speed)
0 	Infinitely variable selector with off (speed is increasing from 0 setting)
	Arrow (action in the direction of arrow)
	Alternating current (type or a characteristic of current)
	Direct current (type or a characteristic of current)
	Alternating or direct current (type or a characteristic of current)
	Class II construction (designates double insulated construction tools)
	Earthing terminal (grounding terminal)

Symbols

Important: Some of the following symbols may be used on your tool. Please study them and learn their meaning. Proper interpretation of these symbols will allow you to operate the tool better and safer.

Symbol	Designation / Explanation
	Alerts user to read manual
	Alerts user to wear eye protection
	This symbol designates that this tool is listed by Underwriters Laboratories.
	This symbol designates that this component is recognized by Underwriters Laboratories.
	This symbol designates that this tool is listed by Underwriters Laboratories, to United States and Canadian Standards.
	This symbol designates that this tool is listed by the Canadian Standards Association.
	This symbol designates that this tool is listed by the Canadian Standards Association, to United States and Canadian Standards.
	This symbol designates that this tool is listed by the Intertek Testing Services, to United States and Canadian Standards.
	This symbol designates that this tool complies to NOM Mexican Standards.
	Designates Li-ion battery recycling program
	Designates Ni-Cad battery recycling program

Getting To Know Your Table Saw

1. POWER SWITCH

Switch incorporates a locking hasp for use with padlock to prevent accidental starting.

2. TABLE

Provides large working surface to support workpiece.

3. BASE / SUB-BASE

Supports table saw. Sub-base provides additional stability and ability for easy sliding onto surfaces. Holes are provided in base to bolt the saw to a workbench or stand.

4. BLADE BEVEL LOCK HANDLE

Locks the blade to desired bevel angle.

5. TABLE EXTENSION

Provides a larger work surface for wider workpieces.

6. TABLE EXTENSION LOCK HANDLE

Allows you to lock the table extension at desired distances.

7. ELEVATION WHEEL

Elevates or lowers the blade. Use with Blade Bevel Lock Handle **4** to tilt the blade 0 to 45 degrees.

8. BLADE BEVEL SCALE

Shows the degree the blade is tilted.

9. RIP FENCE SCALE

Shows the distance from the blade to rip fence through a convenient viewing and magnifying window. Lower portion of scale can be used up to 14.5 inches. Upper portion of scale is used for cuts beyond 14.5 inches.

10. MITER GAUGE

Head can be locked at desired angle for crosscutting or mitering by tightening the lock knob. ALWAYS SECURELY LOCK IT WHEN IN USE.

11. RIP FENCE STORAGE

Conveniently stores rip fence when not in use.

12. PRE-CUT (KERF) INDICATOR

Allows you to mark and locate exactly where the blade will enter the workpiece.

13. MITER GAUGE STORAGE

Conveniently stores miter gauge when not in use.

14. BLADE STORAGE AND WRENCH

Allows you to store 10" blades and arbor wrench.

15. HEX WRENCH

Hex wrench is used for maintaining saw alignment.

16. CORD WRAP

Allows you to easily secure the cord so it's out of the way when transporting or storing.

17. VACUUM HOOK-UP

Your table saw is equipped for vacuum hook-up. This feature will allow you to attach any 2-1/4" vacuum hose into the dust port provided for convenient sawdust removal. An adaptor is available for use with alternate hose sizes.

18. RIP FENCE

Exclusive Self-Aligning, Squarelock rip fence can be easily moved or locked in place by simply raising or lowering lock handle.

19. SMART GUARD SYSTEM

Consists of three key elements: Adjustable (3 position) Riving Knife, Anti-Kickback Device, and Barrier Guard Device. All of these are part of a modular system that requires no tools to assemble or unassemble. This Guard System must always be in place and working properly for all thru-sawing cuts.

20. SMART GUARD SYSTEM STORAGE

When not in use, the Main Barrier Guard and Anti-Kickback Device can be stored under the right side table extension.

21. TABLE INSERT

Removable for removing or installing blade or other cutting tools.

22. PUSH STICK

Allows you to rip smaller pieces of stock with a greater level of safety.

23. PUSH STICK HOLDER

Securely stores push stick when not in use.

24. MOUNTING HOLES

Used to secure the saw to a work stand or bench.

25. THIN WORKPIECE FENCE

Used when ripping workpieces 1/8 of an inch or thinner.

26. THIN WORKPIECE FENCE STORAGE

Used to store thin workpiece fence in combination with cord wraps **16**.

27. BOTTOM SCREEN

Attached to underside of base, the bottom screen prevents unintended access to inside of the saw.

28. POWER CORD

Getting To Know Your Table Saw

Fig. 1

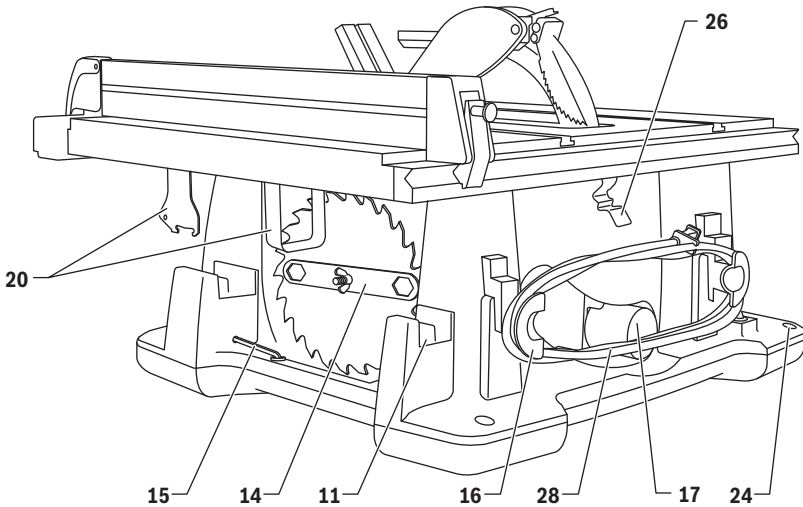
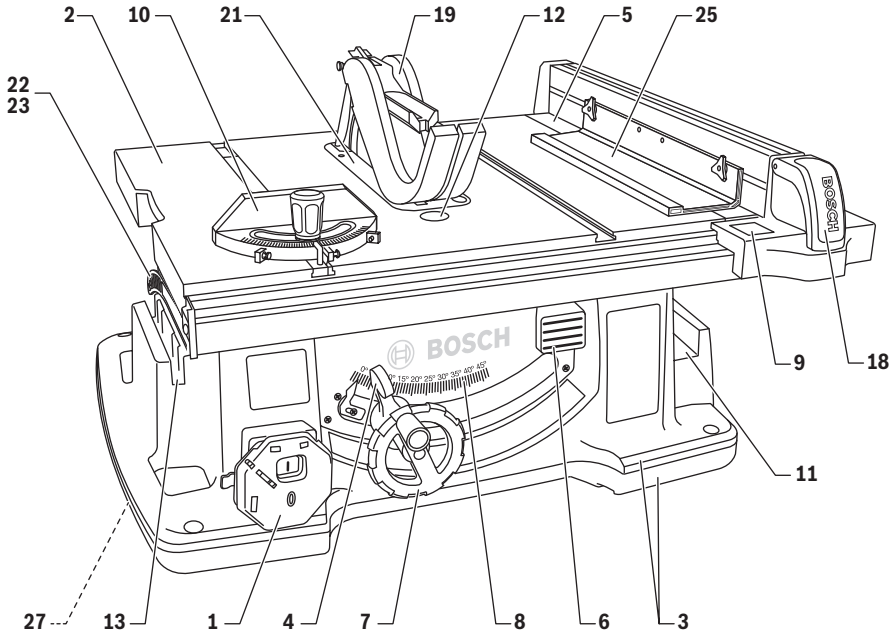

Glossary of Terms

ANTI-KICKBACK DEVICE (also known as dogs or pawls): Spring-loaded pawls that engage the work piece as it is being fed through the saw. They restrict movement of the work piece back in the direction of the operator.

ARBOR: The shaft on which a cutting tool is mounted.

BARRIER GUARD: An assembly that consists of the mounting fork and two side barriers. This assembly is intended to provide a physical barrier between the operator and the spinning saw blade.

BEVEL: Blade angle relative to the table surface.

CROSSCUT: A cutting or shaping operation made across the width of the workpiece cutting the workpiece to length.

DADO: A non-through cut which produces a square sided notch or trough in the workpiece.

FEATHERBOARD: A device which can help guide workpieces during rip type operation by keeping workpiece in contact with the rip fence. It also helps prevent kickback.

FREEHAND: Performing a cut without a fence, miter gauge, fixture, hold down or other proper device to keep the workpiece from twisting during the cut and can be a safety hazard.

GUM: A sticky, sap-based residue from wood products. After it has hardened, it is referred to as "RESIN".

HEEL: Misalignment of the blade which causes the trailing or outfeed side of the blade to contact the cut surface of the workpiece. Heel can cause kickback, binding, excessive force, burning of the workpiece or splintering. In general, heel creates a poor quality cut and can be a safety hazard.

KERF: The space in the workpiece where the material was removed by the blade.

KICKBACK: An uncontrolled grabbing and throwing of the workpiece back toward the front of the saw during a rip type operation.

LEADING END: The end of the workpiece which, during a rip type operation, is pushed into the cutting tool first.

MOLDING: A non-through cut which produces a special shape in the workpiece used for joining or decoration.

NON THROUGH SAWING: Any cutting operation where the blade does not extend through the workpiece (e.g. Dado, Rabbet).

PARALLEL: Position of the rip fence equal in distance at every point to the side face of the saw blade.

PERPENDICULAR: 90° (right angle) intersection or position of the vertical and horizontal planes such as the position of the saw blade (vertical) to the table surface (horizontal).

PUSH BLOCK: A device used for ripping-type operations too narrow to allow use of a Push Stick. Use a Push Block for rip widths less than 2 inches.

PUSH STICK: A device used to feed the workpiece through the saw during narrow ripping-type operation and helps keep the operator's hands well away from the blade. Use the Push Stick for rip widths less than 6 inches and more than 2 inches.

RABBET: A notch in the edge of a workpiece. Also called an edge dado.

REVOLUTIONS PER MINUTE (R.P.M.): The number of turns completed by a spinning object in one minute.

RIPPING: A cutting operation along the length of the workpiece cutting the workpiece to width.

RIVING KNIFE OR SPREADER: A device that keeps the kerf of the work piece open as the material is cut. This minimizes the potential of the work piece binding against the saw blade.

SMART GUARD: A system made up of 3 components: Riving Knife / Splitter, Anti-Kickback Device, and Main Barrier Guard.

THROUGH SAWING: Any cutting operation where the blade extends through the workpiece.

THROWBACK: Event when a small cut-off piece is caught by the back of the blade and thrown toward the operator.

WORKPIECE: The item on which the cutting operation is being performed. The surfaces of a workpiece are commonly referred to as faces, ends and edges.

Assembly

Attaching Bottom Screen

⚠ WARNING Disconnect plug from power source before performing any assembly, adjustment or repair to avoid possible injury.

After removing styrofoam block (see Fig. 3), align screen mounting holes with base mounting tabs.

Lower the screen **27** down (**A**), slide to the right (**B**), then fasten with screw **27a** (Fig. 4). Periodically inspect the bottom screen for trapped debris and clean if necessary.

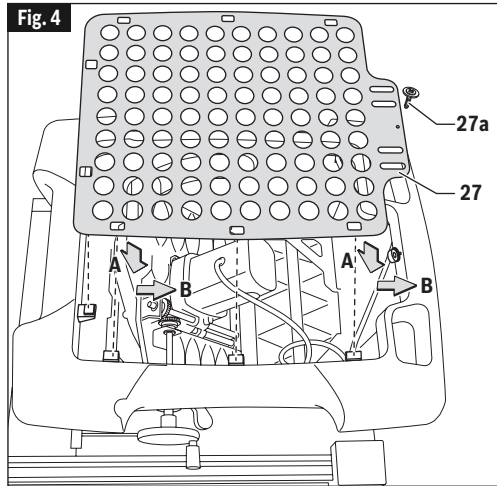

Attaching the Smart Guard System

⚠ WARNING To prevent personal injury, always disconnect plug from power source before attaching or removing the Smart Guard System.

POSITIONING THE RIVING KNIFE

⚠ WARNING Fully secure the riving knife before using the table saw. A loose riving knife may slip into blade and be thrown towards you.

1. Remove table insert **21** using finger hole (Fig. 1).
2. Raise the blade as high as it will go by rotating elevation wheel **7** clockwise and set the blade perpendicular to table [0° on bevel scale] (Fig. 1).
3. Rotate the riving knife release lever **1** clockwise, so that it points upward (Fig. 5).
4. Pull riving knife **2** towards release lever by disengage it from the pins **3** (Fig. 6).
5. Slide the riving knife up to its highest position, so that it is directly over the center of the blade (Fig. 6).
6. Align holes in riving knife with pins **3** and ensure pins engage riving knife holes. Lock the riving knife release lever by rotating it counterclockwise. Firmly push lock lever to secure riving knife then push/pull riving knife to verify that it is locked in place. The indicator lines **4** on the lever and clamp **5** must be aligned as shown (Fig. 6).
7. Check alignment of the riving knife with the blade before replacing table insert and attaching the guard assembly (refer to

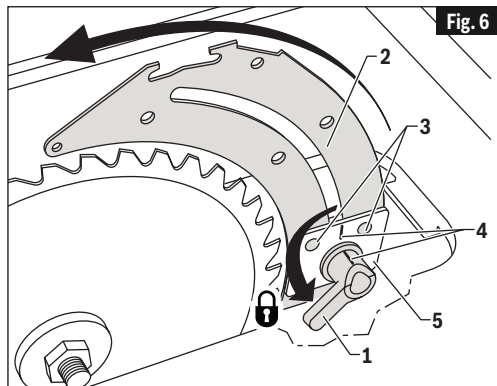
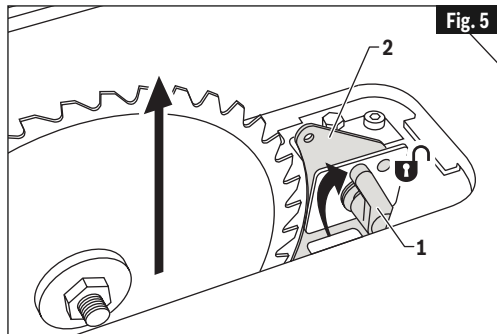

“Riving Knife Alignment” section on page 26). If not aligned with the blade, then repeat the process of positioning the riving knife and be sure that the pins are fully engaged in the riving knife holes.

8. Replace table insert (Fig. 7).

Assembly

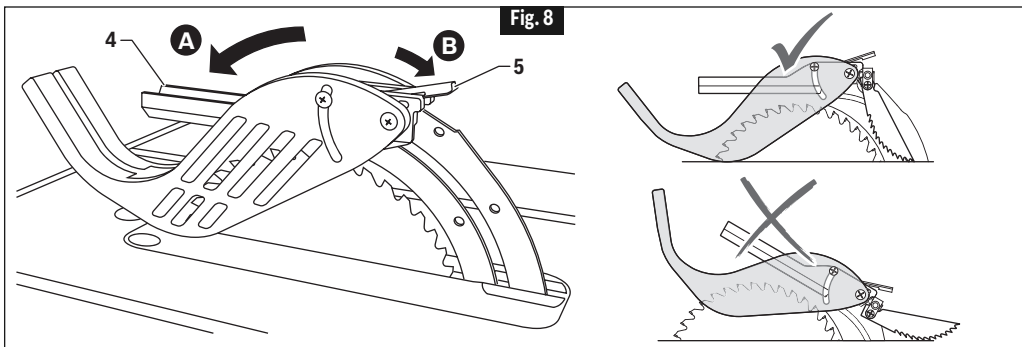
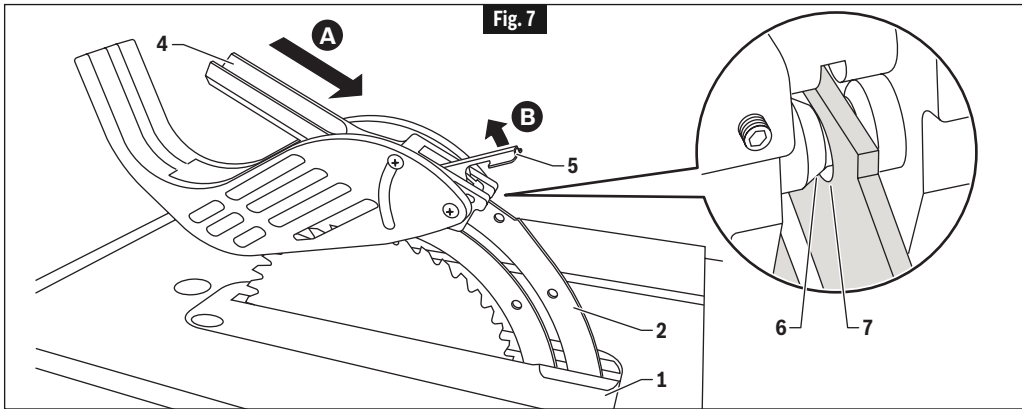

ATTACHING THE GUARD ASSEMBLY

9. With one hand, hold the front of the barrier guard assembly by the "fork" 4. With the other hand, hold the guard release lever 5 up (Fig. 7).
10. Lower the rear of guard assembly and slip the cross bar 6 into the rear notch 7 on top of the riving knife 2 (Fig. 7).
11. Lower the front of the guard assembly until the "fork" is parallel with the table (Fig. 8).
12. Press down on the guard release lever until you feel and hear it snap into the locking position. Check that the guard assembly is securely connected (Fig. 8).

ATTACHING THE ANTI-KICKBACK DEVICE

13. Attach the anti-kickback device 7 into the flat recessed area 8 of the riving knife 2 (Fig. 9).

14. Squeeze the compression pins 9 while nesting the device into the flat area (Fig. 9).
15. Release the compression pins such that the anti-kickback device locks onto the riving knife immediately behind the guard assembly. Check that the attachment pin is securely connected into locking hole. Carefully raise and lower the pawls 10 – when letting go, the spring-loaded pawls must come down and contact the table insert (Fig. 9).

Tip: Position the Anti-kickback device behind the flat recessed area and slide it towards the front until it drops into the recessed area – then release the compression pins.

Note: The two attachments are independent of each other, so the anti-kickback device can be attached before the Guard Assembly.

Assembly

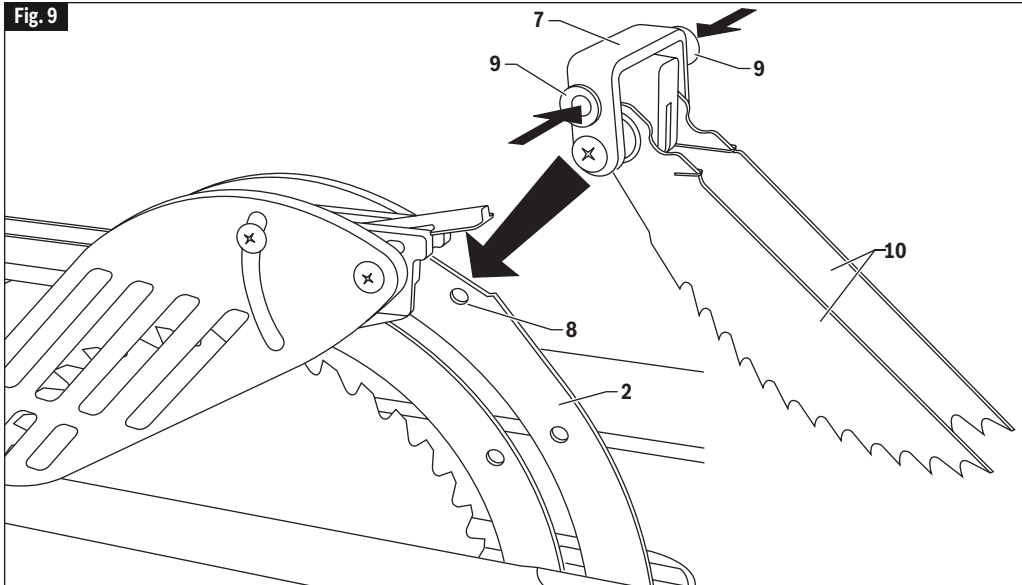

Selecting and Changing the Blade

⚠ WARNING To prevent personal injury, always disconnect plug from power source before changing blades.

USING THE CORRECT BLADE

IMPORTANT: The saw blade provided on this tool has a carbide-tipped kerf width of .102" (2.6mm) and a plate (body) thickness that is .071" (1.8mm) thick. When looking for a replacement blade, select one with dimensions close to the original blade. This information may not be printed on the blade's packaging. If not, check the manufacturer's catalog or website. Bosch offers an extensive line of Premium-Quality Professional Saw Blades that match the requirements for this tool. You must select a blade with a kerf width of .092" (2.3mm) or more and a plate (body) thickness .088" (2.2mm) or less (Fig. 10).

⚠ WARNING To reduce the risk of injury, do not use extra thin kerf saw blades. The kerf of the blade must be wider than .092" (2.3mm). Extra thin kerf saw blades (less than .092" [2.3mm]) may cause the work piece to bind against the riving knife during cutting. It is recommended

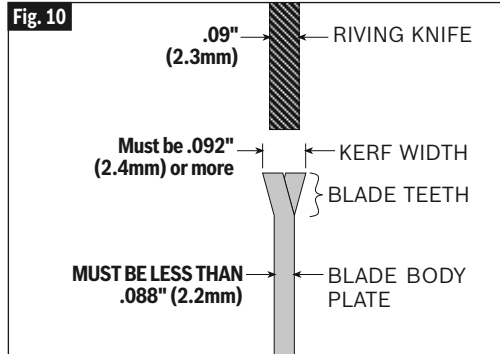

that the kerf of the replacement blade used on this saw be .092" (2.3mm) or more.

⚠ WARNING To reduce the risk of injury, do not use saw blades made with a thick body plate. If the replacement saw blade's plate thickness is greater than .088" (2.2mm), the riving knife would not properly serve as an aid to reduce kickback. The replacement blade's plate thickness must be less than .088" (2.2mm).

⚠ WARNING To reduce the risk of injury, do not use blade "dampeners," "stabilizers," or "stiffening collars" on both sides of a replacement blade. These are metal plates positioned against the sides of the blade to reduce de-

Assembly

flexion that may occur when using thin saw blades. Use of these devices on both sides will prevent the blade from being properly aligned with the riving knife, which may bind the work piece during cutting. One “stabilizer” plate may be placed only against the outside of a thin replacement blade. These plates are not required with the supplied Bosch blade.

CHANGING THE BLADE

CAUTION Always wear gloves when changing or handling blades. Blade tips can cause personal injury.

1. Turn elevation wheel **9** (Fig. 1) clockwise until the blade is up as high as it will go, remove table insert **1** using finger hole (Fig. 11).
 2. Lift up arbor lock lever **2** and slowly rotate blade by hand until lock fully engages saw arbor and stops rotation (Fig. 11). Loosen arbor nut **3** counter clockwise with the arbor wrench **4** provided (Fig. 12). Set arbor wrench aside and continue to loosen arbor nut by hand and remove arbor nut and outer washer **5**. Blade may now be removed or installed by sliding on or off arbor shaft **6**.
 3. Assemble inner washer **7** and new blade as shown in figure 13, making certain the TEETH OF THE BLADE ARE POINTING DOWN AT THE FRONT OF THE TABLE.
- NOTE:** The printing on different saw blades are not always on the same side.
4. Assemble outer washer **5**, arbor nut **3** as shown in figure 13. While lifting up arbor lock lever **2** securely tighten arbor nut clockwise with the arbor wrench **4** (Fig. 12).
 5. Position table insert **1** in pocket of table so tabs **8** on table insert are in slots in pocket of table and push down and secure in place.

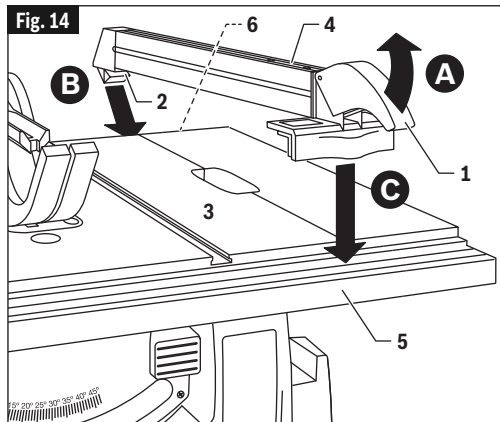
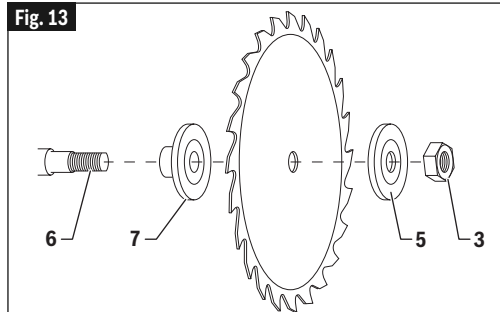
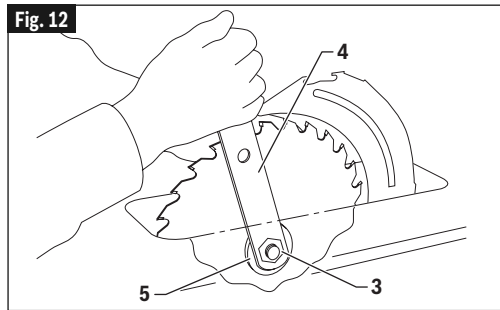
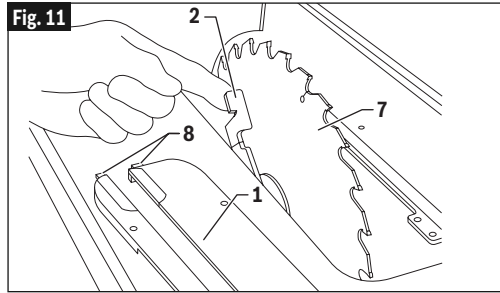

Attaching Rip Fence

- A. Raise rip fence handle **1**, so holding clamp **2** is out far enough to fit on the table **3** and into “V” groove located on the back of rear rail **6** (Fig. 14).
- B. Position the rip fence **4** over table **3** holding up the front end, first engage holding clamp **2** with rear rail.
- C. Lower front end onto front rail **5**.

Assembly

Attaching Thin Workpiece Fence

Make sure the fasteners **25a** are in the outer two holes. Slide the rip fence **18** away from the blade. Set the thin workpiece fence on the table, turn the fasteners so that the heads align with the slot **18a** on the rip fence.

Slide the thin workpiece fence towards the rip fence handle **18b** and align the front edge of the thin workpiece fence with edge of the table **2**. Tighten the fasteners (Fig. 14a).

Set the thin workpiece fence to the desired distance from the blade. **NOTE:** the thin workpiece fence is 3" (76mm) wide. When using the rip fence scale, subtract 3" (76mm) from the scale reading to get the desired setting. For example, a scale reading of 4-1/2" (114mm) positions the thin workpiece fence 1-1/2" (38mm) from the blade.

To remove the Thin Workpiece Fence, loosen fasteners and reverse the installation steps. After removal, tighten fasteners to prevent loss. Store Thin Workpiece Fence as shown on page 22.

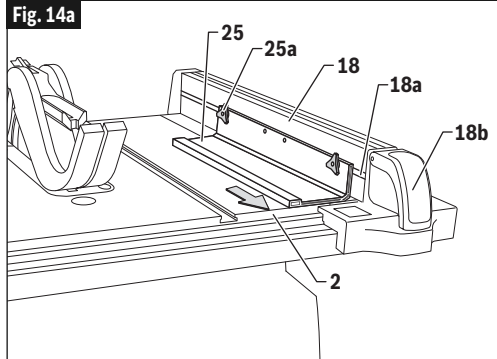

Storage, Transportation, and Mounting

MITER GAUGE AND PUSH STICK STORAGE

When not in use, store miter gauge **10** in miter gauge storage slot **13** on the left side panel of the saw (Fig. 15).

When not in use, slide push stick **22** into push stick storage slot **23**. Make sure to insert push stick handle first as shown in Fig. 15.

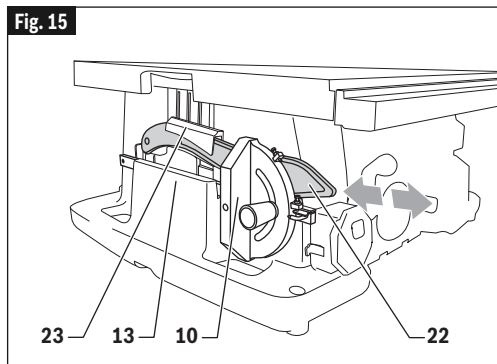

Storage, Transportation, and Mounting

RIP FENCE AND THIN WORKPIECE FENCE STORAGE

- When not in use, store rip fence **18** in rip fence storage **11** on the right side panel of the saw (Fig. 16).
- Store the blade wrench **14** in its dedicated area, secured with a wing nut **14a** (Fig. 16).
- Wrap the power cord **28** around the cord wrap **16** (Fig. 16).
- Mount the 5mm hex wrench **15** in its dedicated storage location on the right side of the base (Fig. 16).
- To store the thin workpiece fence **25**, lift the clip **26** and place the fence on the “shoulders” of the red cord wraps **16** as shown. Release the clip **26** to secure the fence **25** in place.

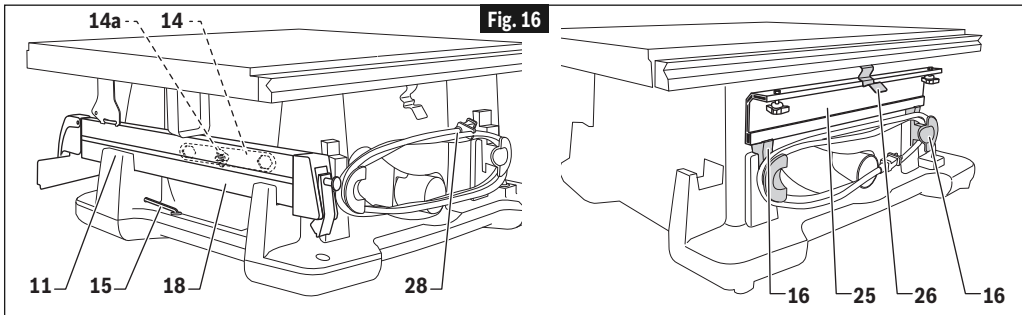

SMART GUARD SYSTEM STORAGE

⚠ WARNING Use of all the components of the Smart Guard System, including Main Barrier Guard, Anti-Kickback Device, and Riving Knife is highly recommended to provide protection against accidents and injury.

When not in use, the main barrier guard and anti-kickback device can be stored under the right side table extension.

- Slide the main barrier guard assembly **19a** (upside down) up and back into the strap support **20b** at the rear right side of the saw (Fig. 17).
- Pivot the rear of the guard up and into the front mounting bracket **20a** (Fig. 17).
- Lock the main barrier guard assembly **19a** into place in the same manner as you would attach it to the riving knife (Fig. 18).
- Attach the anti-kickback device **19b** to the front mounting bracket in the same manner that it attaches to the riving knife (Fig. 18).

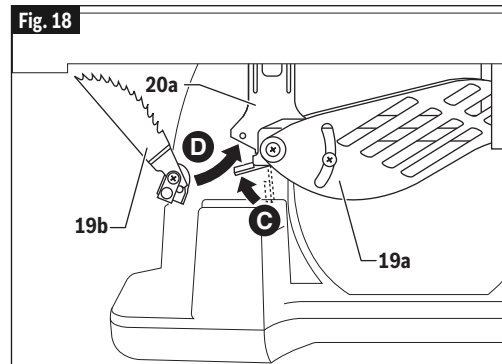
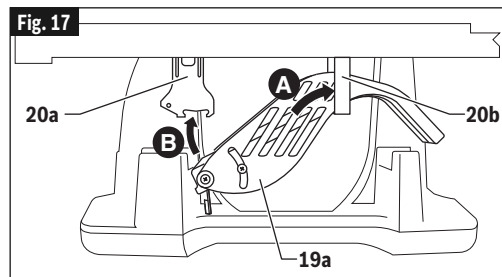

Storage, Transportation, and Mounting

MOUNTING THE TABLE SAW

If table saw is to be used in a permanent location, it should be fastened securely to a firm supporting surface such as a stand or workbench, using the four mounting holes **24** (Fig. 19).

1. If mounting to a workbench, the base should be bolted securely using 5/16" (M8) hex bolts (not included) through mounting holes.

Hint: If workbench is 3/4" (19mm) thick, bolts will have to be at least 3-1/2" (90mm) long - if workbench is 1-1/2" (38mm) thick, bolts should be at least 4-1/2" (114mm) long.

2. Locate and mark where the saw is to be mounted, relative to holes in the base of the tool.
3. Drill four (4) 3/8" (9.5mm) diameter holes through workbench.
4. Place table saw on workbench aligning holes in base with holes drilled in workbench.

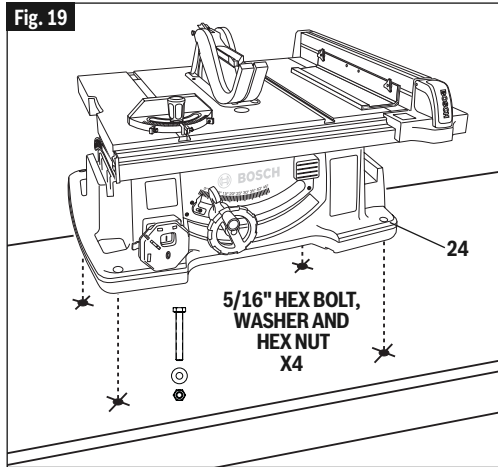

5. Insert four (4) 5/16" dia. bolts through holes in base and supporting surface; then secure with (4) 5/16" flat washers and (4) 5/16" hex nuts (hardware not included).

Adjustments

Adjusting Blade Parallel to the Miter Gauge Slots

⚠ WARNING To prevent personal injury, always disconnect the plug from power source before making any adjustments.

The blade was adjusted parallel to the miter gauge slots at the factory. In order to ensure accurate cuts and help prevent kickback, this adjustment should be rechecked. If adjustment is necessary, follow the steps below.

1. Turn elevation wheel **7** (Fig. 1) and raise blade as high as it will go.
2. Select a point on the body of the saw blade that is set to the left when viewing blade from the front of saw, and mark **1** with a pencil (Fig. 20).
3. Place the base of a combination square against the edge of the miter gauge slot, and extend the sliding rule of square so it just touches the marked point **1** on the body of the saw blade at the rear of the table.

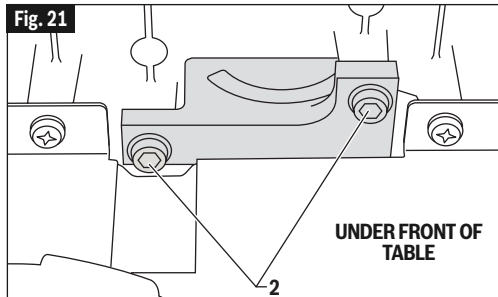
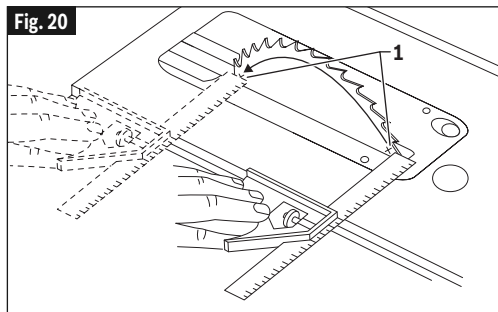

Adjustments

4. Rotate blade and check the same marked point **1** of the saw blade at the front of the table (Fig. 20).
5. If the front and back measurements, shown in Figure 22, are not identical, loosen the four alignment bolts **2**, located on the underside of the table at the front and rear of the saw with hex wrench supplied with your saw (Fig. 21 and 22). Carefully move the saw blade until the blade is parallel to the miter gauge slot, and securely tighten all four bolts.

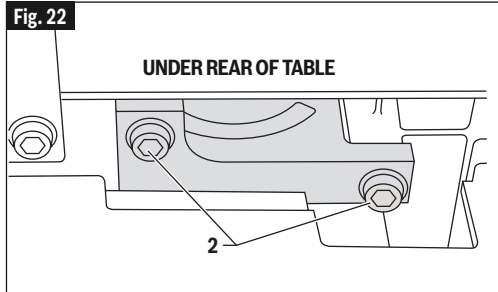

MITER GAUGE ADJUSTMENT

To check your miter gauge accuracy, move the miter gauge in line with blade and use a combination square to make sure the miter gauge body is 90 degrees to the blade (Fig. 23).

To adjust the miter gauge for 90 degrees:

1. Loosen lock nut **3**, adjustment screw **4**, and lock knob **5**.
2. Flip stop plate **6** down.
3. Rotate miter gauge body until it is 90 degrees to the blade.
4. Tighten lock knob **5**.
5. Flip stop plate **6** up and tighten adjustment screw **4** until it contacts stop plate.
6. Tighten lock nut **3**.
7. If pointer **7** is not pointing to 90 degrees, loosen set screw **8** on side of miter gauge bar and rotate pointer **7** to 90 degree mark. Tighten set screw **8**.
8. To adjust the miter gauge for 45 degree left and right, repeat steps 1–6, but use 45 degree stops.

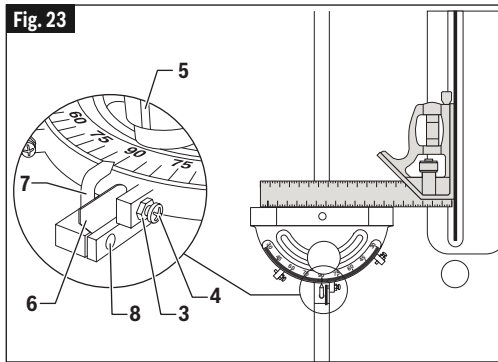

Adjustments

Rip Fence Adjustments

ALIGNING RIP FENCE

⚠WARNING To prevent personal injury, always disconnect plug from power source before making any adjustments. The rip fence must be parallel with the SAWBLADE in order to prevent KICK-BACK when ripping.

⚠WARNING To prevent personal injury, always make sure the rip fence is locked before making rip cuts.

Your table saw is equipped with a self-aligning, quick-set rip fence. Once the adjustments below have been made, the rip fence will self align when the rip fence is locked into position.

NOTE: The blade must be parallel with the miter gauge slots (refer to "Adjusting Blade Parallel to the Miter Gauge Slots" section, page 23) and be perpendicular to table before proceeding with rip fence alignment.

1. Lift both guard barriers **2** to their up locked position.
2. Raise lock handle **1** and slide rip fence **3** until it is alongside the sawblade, by lifting right side pawl **4** above rip fence (Fig. 24).

The rip fence should touch the blade teeth at the front and rear of the blade. If rip fence does not touch the teeth at front and rear of blade continue with the following the steps:

3. Loosen the two screws **5** on the top front section of the rip fence using the included 5mm hex wrench.
4. Move rip fence **3** until it touches the teeth and is parallel to the blade.
5. Hold rip fence in place and lower lock handle, check to make sure the rip fence stayed parallel to the blade then tighten screws (Fig. 24).
6. Clamp rip fence to check if it holds securely at front and rear. If rear is not clamped securely, unclamp rip fence and turn rear clamp adjustment screw **6** clockwise for increased clamping. Try clamping the rip fence to verify if it self aligns and clamps tightly at the front and rear. Overtightening of the rear clamp adjustment screw **6** will cause the rip fence to be non-self aligning (Fig.

24). Overtightening may cause friction or "chatter" when rip fence is moved side to side.

RIP FENCE POINTER ADJUSTMENT

The distance of the rip fence body from the blade when ripping on the right side of the blade is determined by lining the rip fence pointer **7** with the desired dimension on the scale **8** (Fig. 25).

TO SET THE RIP FENCE POINTER:

1. Lift both guard barriers **2** to their up locked position (Fig. 24).
2. Raise lock handle **1** and slide rip fence **3** until it is alongside the sawblade, by lifting right side pawl **4** above rip fence (Fig. 24).
3. Loosen pointer adjustment screw **9**, adjust pointer **7** to "0" mark on lower scale **8**, then re-tighten screw **9** (Fig. 25).

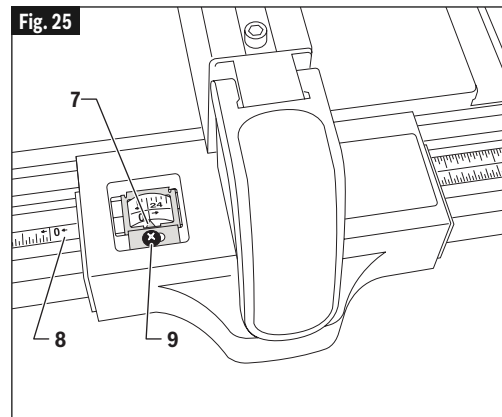
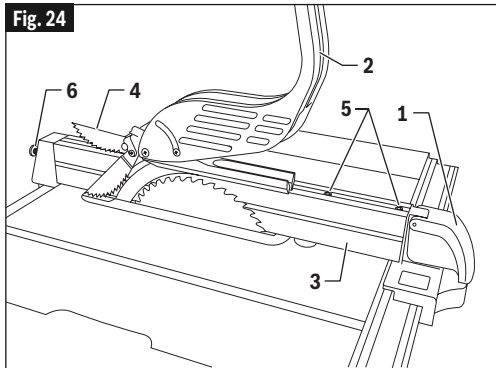

Adjustments

Table Pointer Adjustment

If an adjustment to the table pointer is necessary, loosen pointer adjustment screw **1**, adjust pointer **2** and tighten screw (Fig. 26). The table pointer should always be adjusted relative to rip fence pointer.

1. Adjust rip fence pointer **7** to (zero) - see "Rip Fence Pointer Adjustment" (Fig. 25).
2. Slide rip fence to the right until it hits the stop plate on front rail and lock rip fence in place.
3. Look at rip fence pointer and note measurement on lower scale (at or near 14.5").
4. Adjust the table pointer **2** to the same reading on upper scale as that shown on the rip fence pointer. Both pointers must agree when rip fence is at this position.

Example: If rip fence pointer is at 13-9/16", then table pointer should also be set at 13-9/16".

Riving Knife Alignment

⚠ WARNING To prevent personal injury, always disconnect plug from power source before making any adjustments and when attaching or removing the Smart Guard System.

IMPORTANT: The riving knife **1** must always be in line with the saw blade **2**. The riving knife **1** is thinner than the width of the kerf **4** by approximately two thicknesses of standard 20 lb. (75gsm) copy paper **5** on each side (Fig 27). **Note:** The kerf is the width of the cut made by the teeth on the saw blade.

CHECKING RIVING KNIFE ALIGNMENT

NOTE: The riving knife has been properly aligned at the factory - Check the alignment before making any adjustments.

1. Turn elevation wheel **7** (Fig. 1) clockwise to raise blade to maximum height and set the bevel angle to 0°.
2. Remove the barrier guard assembly and anti-kickback device.
3. Place the rip fence **3** on the right side and slide it until it touches the tips of the saw blade **2** - Lock rip fence (Fig. 28).
4. Check the alignment:
 - A. From the top, look down over the rip fence and check that the riving knife is in line (front to back) with the blade and

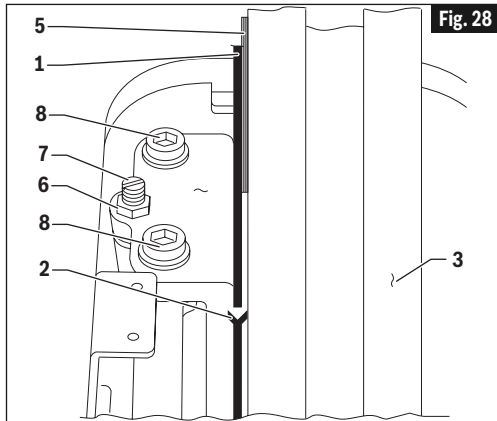
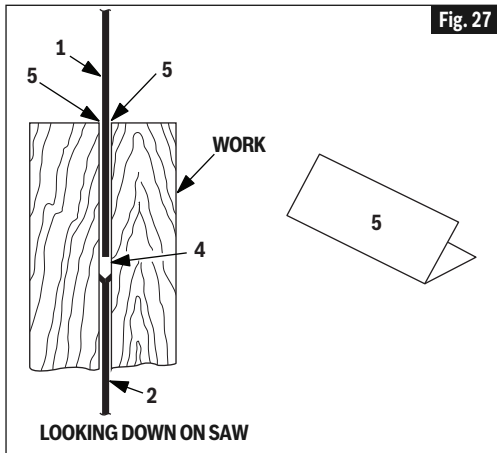
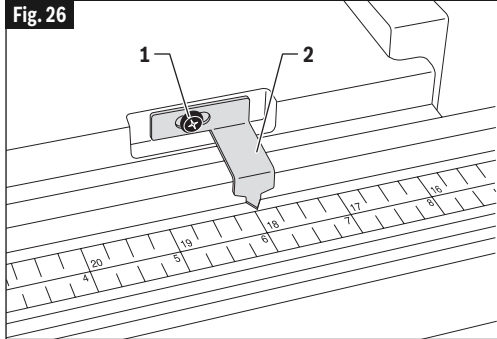

parallel with the rip fence.

- B. Slide the rip fence away from the blade. Look over the front of the blade and check that the riving knife is in line with the blade.

Adjustments

- C. If steps A or B show misalignment, proceed to "Adjusting Riving Knife".

ADJUSTING RIVING KNIFE

1. Raise the saw blade **2** to maximum height and set the bevel angle to 0°.
 2. Remove the barrier guard assembly and anti-kickback device.
 3. Remove the table insert.
 4. Place the rip fence **3** on the right side and slide it until it touches the tips of the saw blade **2** - Lock rip fence.
 5. Loosen Hex Nut **6** with 10mm open end wrench (Fig. 28). Slightly loosen clamping screws **8** (1/4-1/2 turns) using a 5mm hex wrench **15** provided with table saw (stored in right side of base). Loosen set screw **7** using a flat screwdriver (Fig. 28).
 6. Fold a small (6" x 6" [152x152 mm]) piece of standard 20 lb. (75gsm) copy paper forming two layers (Fig. 27). The paper **5** is used as a "Spacing Gauge".
- NOTE:** The spacing instructions above are based on using a standard kerf blade (.128" [3.25mm] kerf on the Bosch blade included). If a smaller kerf blade is used, adjust the paper spacer. For instance, if the kerf of the replacement blade is near .100" (2.54mm), use 1 thickness of paper as a spacer; if the kerf is near .110" (2.8mm), use 2 thicknesses.
7. Insert folded paper **5** between riving knife **1** and rip fence **3**.
 - A. Hold riving knife and paper firmly against rip fence (Fig. 28 and 29).
 - B. Lightly tighten the clamp screws **8**.
 - C. Remove the paper - Slide rip fence away from blade.
 - D. Slowly turn the set screw **7** while watching the riving knife tilt until it is in line with the blade.
 - E. Recheck squareness of riving knife to table by sliding rip fence against blade. Readjust if necessary.
 8. After completing adjustments:
 - A. Lightly tighten hex nut **6** (hold set screw position with screwdriver while tightening nut).
 - B. Fully tighten clamp screws **8** with hex wrench **15**. Then fully tighten the hex nut.

NOTE: Check that the riving knife stays in line

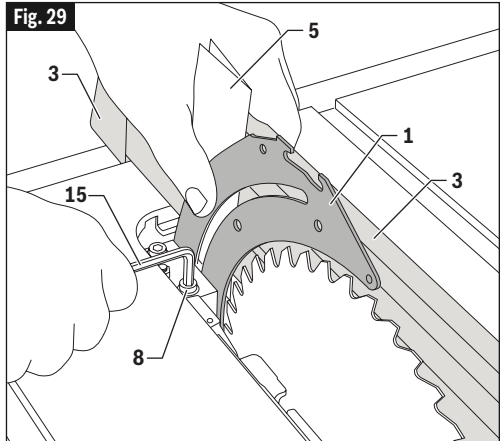

with blade when the blade is tilted at any angle. Replace the barrier guard assembly and anti-kickback device before making cuts.

Adjusting the Table Insert

The table insert includes four (4) adjustment screws **3** to set the height (Fig. 30). Place the insert onto the table. Place a straight edge (such as the metal ruler from a combination square) across the table top and insert top - the surfaces should be at the same level. If adjustment is necessary, use a small slotted screwdriver to rotate each set screw.

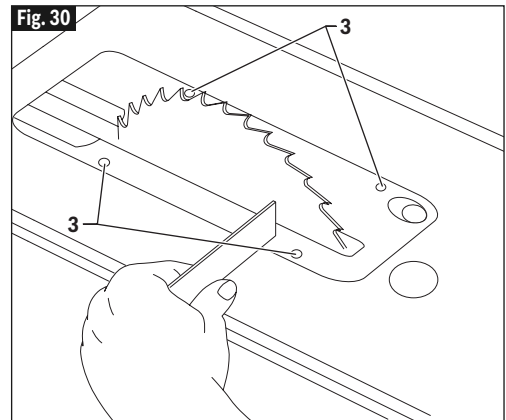

Adjustments

Adjusting 0 and 45 Degree Positive Stops

⚠WARNING To prevent personal injury, always disconnect plug from power source when making adjustments.

Your saw is equipped with positive stops for fast and accurate positioning of the saw blade at 90 and 45 degrees to the table.

1. Turn elevation wheel **2** clockwise and raise blade to maximum height (Fig. 31).

ADJUSTING 0 DEGREE POSITIVE STOP:

2. Loosen the blade tilt lock handle **1** and push the elevation wheel to the left as far as possible and tighten the blade tilt lock handle (Fig. 31).
3. Place a combination square on the table with one end of square against the blade as shown (Fig. 32), and check to see if the blade is 90 degrees to the table. If the blade is not 90 degrees to the table, loosen the blade tilt lock handle, loosen 90 degree adjustment screw **4**, loosen 90 degree bevel stop cam **5** and push the elevation wheel until the blade is 90 degrees to the table.
4. Tighten blade tilt lock handle, rotate the bevel stop cam until it touches the bevel stop housing **7**, then tighten 90 degree adjustment screw **4**.
5. Loosen adjustment screw **6** and adjust pointer **3** to indicate 0 degrees on the bevel scale.

ADJUSTING 45 DEGREE POSITIVE STOP:

6. Loosen the blade tilt lock handle and push the elevation wheel to the right as far as possible and tighten the blade tilt lock handle.
7. Place a combination square on the table with one end of square against the blade as shown (Fig. 33), and check to see if the blade is 45 degrees to the table. If the blade is not 45 degrees to the table, loosen the blade tilt lock handle, loosen 45 degree adjustment screw **8**, loosen 45 degree bevel stop cam **9** and push the

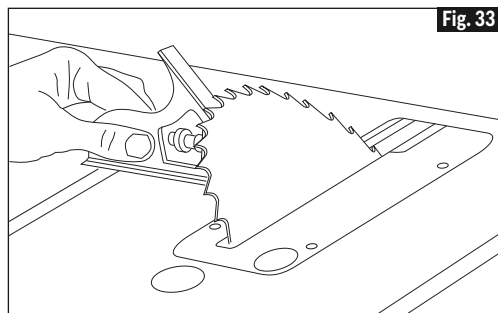
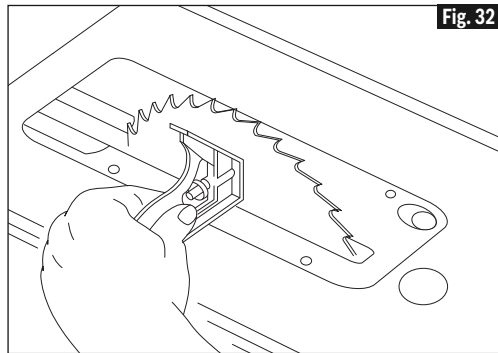
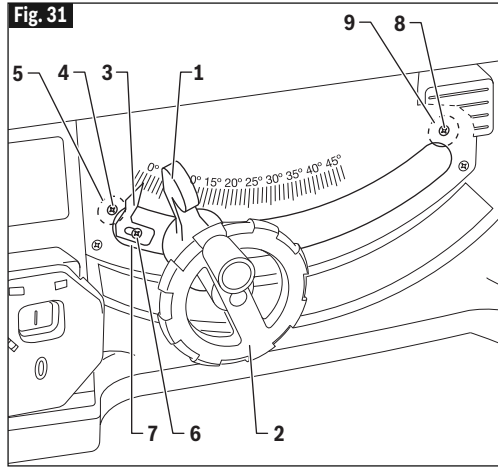

elevation wheel until the blade is 45 degrees to the table.

8. Tighten blade tilt lock handle, rotate the 45 degree bevel stop cam **9** until it touches the bevel stop housing **7**, then tighten 45 degree adjustment screw **8**.

Basic Table Saw Operation

Power Switch

To turn saw on: press the green ON (I) button **1** (Fig. 34).

To turn off power: push the red OFF (O) stop paddle **2** (Fig. 34).

To prevent unauthorized use, lock the switch as follows:

- Lift the primary Stop paddle **2** (Fig. 35a).

- Swing the lock out flap **3** and (Fig. 35a).
- Close the Stop paddle **2**, pull out the locking hasp **4** and secure the switch with a padlock **5** (Fig. 35b). Padlock (not provided with the table saw) must have a 3/16" or 1/4" (4.5 or 6 mm) diameter shackle.

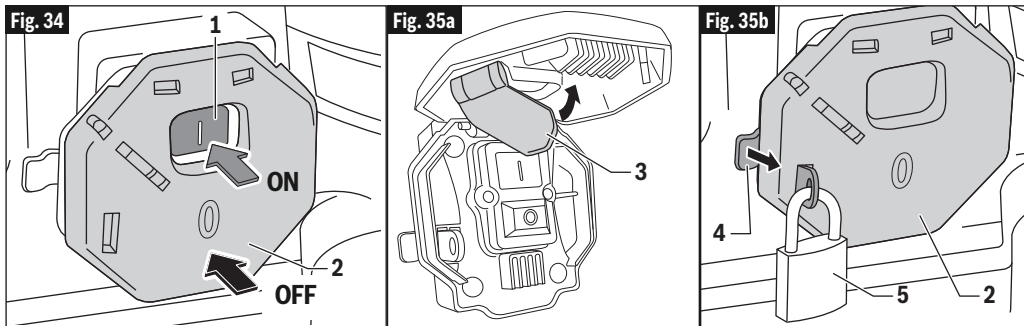

Using the Smart Guard System

The Bosch Smart Guard has been designed for modularity, enabling the use of multiple combinations of the three main components – **1** Riving knife / splitter, **2** Main barrier guard, and **3** Anti-kickback device (Fig. 36). Additionally, the riving knife can be quickly adjusted to three positions depending on the application requirement: through cut (high), non-through cut (middle), and dado (lowest). The three primary guarding components of the Smart Guard blade guarding system are designed for rapid attachment, adjustment, and/or removal without the need for additional tools. Any Smart Guard components that need to be removed to complete a cut should be immediately reinstalled when finished. See pages 17–18 for detailed installation instruc-

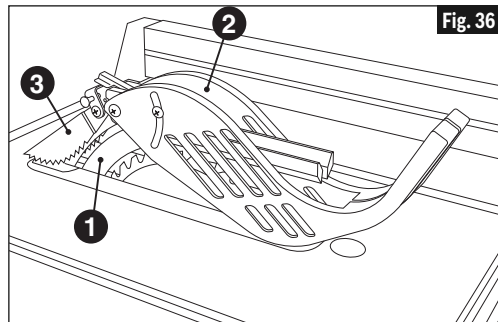

tions. Always remember that the best accident prevention is the operator's use of common sense and alertness at all times when using the table saw.

Basic Table Saw Operation

Fig. 37

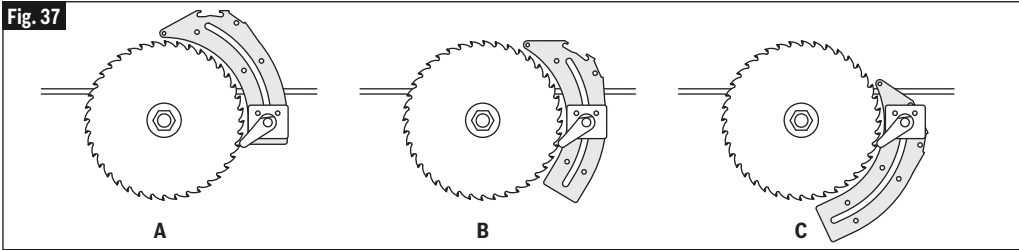

RIVING KNIFE / SPLITTER

The riving knife (splitter) is the central element of the Bosch Smart Guard blade guarding system, serving as the attachment point for both the main barrier guard and the anti-kickback device. In the event that the main barrier guard and anti-kickback device are removed, the riving knife maintains its functionality as material splitter, and can be quickly adjusted to three positions (through cut **A**, non-through cut **B**, and dado **C**), depending on the application requirement (Fig. 37). Because of this adjustability, the riving knife can be appropriately positioned for all cutting applications.

The riving knife (splitter) can be easily adjusted to one of three heights by removing the table insert, raising the blade to its full height and releasing the riving knife release lever at the base of the riving knife. The riving knife should be locked in its through cut (highest) position for use with the main barrier guard and anti-kickback device. It can be adjusted to its non-through cut (middle) position for use as a material splitter without the main barrier guard and anti-kickback device. In the event that the riving knife cannot be used for a specific cut or for use with a dado blade, it can be adjusted to its dado (lowest) position, placing it 1" (25.4mm) above the table surface when the blade is at its full height.

MAIN BARRIER GUARD

The main guard is comprised of a pair of plastic barriers attached to the metal upper barrier guard. The side barriers (one to the left and one to the right of the blade) operate independently of one another, maintaining maximum blade coverage during cutting operations. The main guard incorporates a quick-connect attachment point and can be attached or removed from the blade guarding system independent of the anti-kickback device and riving knife / splitter.

The main barrier guard component can be quickly attached and detached through the use of a quick release lever. The guard is attached by seating the crossbar into the top of the riving knife / splitter and engaging the locking lever. Following this process in reverse, the guard can be easily removed for special operations such as dados or rabbets.

Note: To best secure the main guard for relocation, adjust the blade to its lowest position. This keeps the guard tight to the table surface and prevents damage related to the guard swinging during relocation. If transporting over a longer distance on/off the job, place guard in its below table storage position (See Figure 17, page 22).

ANTI-KICKBACK DEVICE

In the event of kickback, the anti-kickback device is intended to help prevent the board from being thrown in the direction of the user. The sharp teeth of the pawls are intended to "catch" the material in the event of kickback.

The anti-kickback device can be easily attached by aligning the attachment pin with the hole in the rear of the riving knife / splitter. It can be easily re-moved by depressing the compression pads on both sides of the anti-kickback device and lifting it away.

Making Work Helpers

Before cutting any wood on your saw, study all of the "Basic Table Saw Operations".

Notice that in order to make some of the cuts, it is necessary to use certain devices, "Work Helpers", like the push stick, the push block and the auxiliary fence, which you can make yourself.

After you have made a few practice cuts, make these "helpers" before starting any projects. Make the "push stick" first.

Basic Table Saw Operation

MAKING PUSH STICK AND PUSH BLOCK

Make the push stick **1** using a piece of 1 x 2 (19x38mm) as shown (Fig. 38). For proper use of push stick see page 33.

Make the push block **2** using pieces of 3/8" (8.7mm) plywood **3** and 3/4" (19mm) hardwood **4** (Fig. 39). The push block is to be used in combination with the auxiliary fence only. For proper use of push block see page 34.

The small piece of wood, 3/8" x 3/8" x 2-1/2" (9.5 x 9.5 x 63.5mm), should be GLUED to the plywood... DO NOT USE NAILS. This is to prevent dulling the sawblade in the event you mistakenly cut into the push block.

Position the handle in the center of the plywood and fasten together with glue and woodscrews.

Use a push stick whenever the rip fence is 2 inches (50 mm) or more from the blade. Use a push block when the operation is too narrow to allow the use of a push stick. For proper use, see page 33.

Both a push stick or block should be used in the place of the user's hand to guide the material only between the rip fence and blade.

When using a push stick or push block, the trailing end of the board must be square. A push stick or block against an uneven end could slip off or push the work away from the rip fence.

MAKING AUXILIARY FENCE

Make one using pieces of 3/8" (8.7mm) plywood **3** and 3/4" (19mm) hardwood **4**. Fasten together with glue and woodscrews (Fig. 40).

NOTE: Since the push block **2** is used with the auxiliary fence **5**, the 4-3/4" (120.6mm) dimensions must be held identical on both the pieces.

MAKING A FEATHERBOARD

Figure 41 illustrates dimensions for making a typical featherboard. It should be made from a straight piece of wood that is free of knots or cracks.

Kerf **5** should be about 1/4" (6.35mm) apart (Fig. 41).

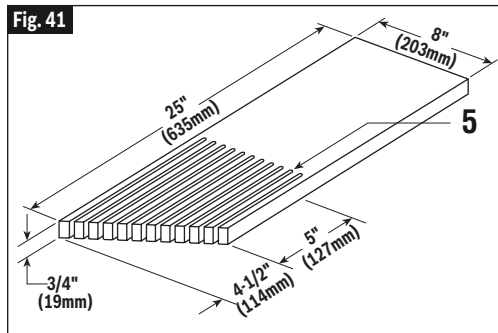
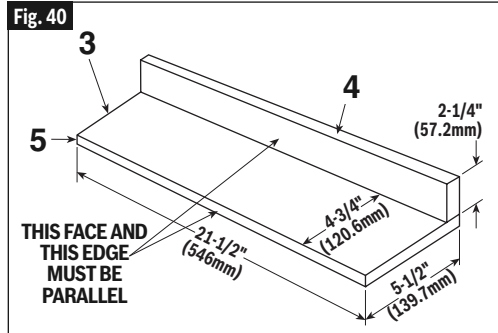
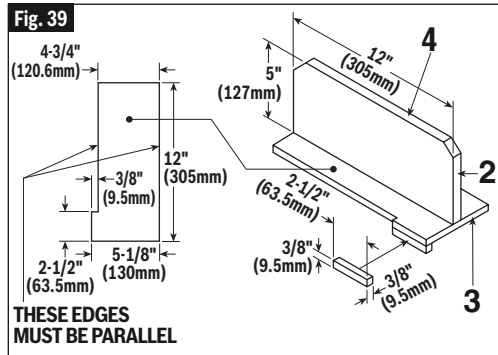
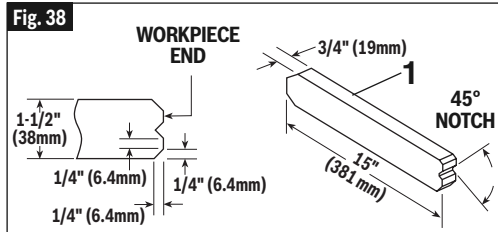

Basic Table Saw Operation

MAKING THE FACING BLOCK

The facing block should be made of 1-1/2 inch (38mm) thick wood – Figure 42 shows dimensions to make a facing block.

Parts Required:

- 1-1/2" thick wood board cut to size (1)
- 1/4 x 20 x 1-1/2" long hex. head machine screws (2)
- 1/4" Washers (2)
- 1/4 x 20 machine nuts (2)

The facing block is made to the same height (2-3/4" [70mm]) as the rip fence and can work with the blade guard system in place when cutoff pieces are 1-1/2 inches (38mm) or greater. Cut the board to the size shown, drill through 9/32" (7mm) holes, then counter-sink each hole (down 3/8 inch [9.5mm]) using a 3/4 inch (19mm) drill bit.

Assembly:

- A. Place the hex. head **1** of each machine screw into the recess **2** in the rear rip fence housing – then slide each screw forward to the locations shown.
- B. Place facing block **3** over screws.
- C. Place washers over screw threads.
- D. Thread and tighten the nuts onto the screws.

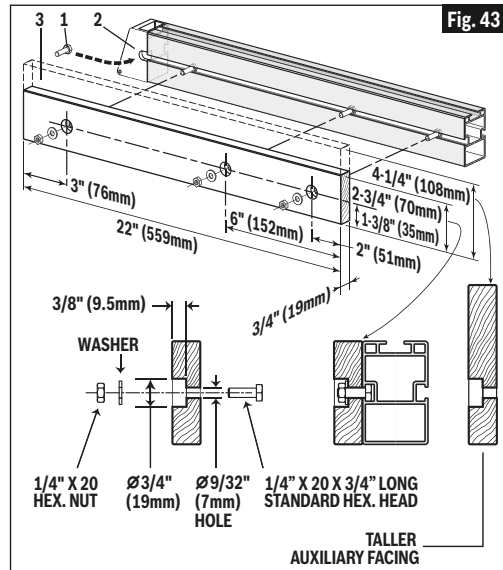
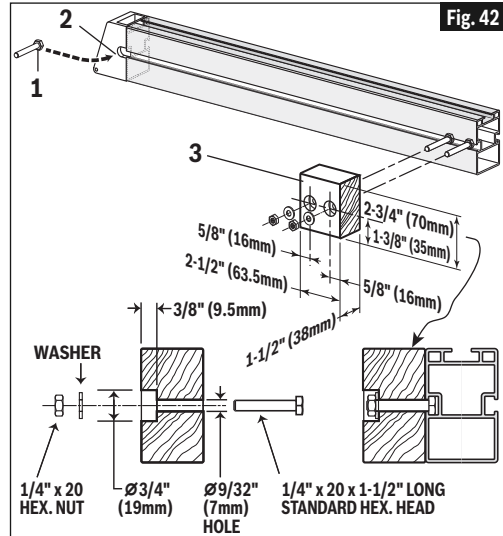

Assembly:

- A. Place the hex. head **1** of each machine screw into the recess **2** in the rear rip fence housing – then slide each screw forward to the locations shown.
- B. Place facing board **3** over screws
- C. Place washers over screw threads
- D. Thread and tighten the nuts onto the screws.

MAKING RIP FENCE AUXILIARY FACING

When using dado or molding head accessories, an auxiliary facing board should be used. This will help prevent damage to the aluminum rip fence. The facing should be made of 3/4 inch (19mm) thick wood – Figure 43 shows dimensional plans to make a facing board to fit this saw.

Parts Required:

- 3/4" (19mm) thick wood board (solid or plywood) cut to size
- Three (3) 1/4 x 20 x 3/4" long hex. head machine screws
- Three (3) 1/4" Washers
- Three (3) 1/4 x 20 machine nuts

The facing is made to the same height (2-3/4" [70mm]) as the rip fence and can work with the blade guard system in place when moving the rip fence to contact the blade. The taller facing design (4-1/4" [108mm]) is optional and can be used for clamping on other accessories. Cut the board to the size shown, drill through 9/32" (7mm) holes, then counter-sink each hole (down 3/8 inch [9.5mm]) using a 3/4 inch (19mm) drill bit.

Basic Table Saw Operation

MAKING MITER GAUGE AUXILIARY FACING

A template for drilling holes in the miter gauge is provided on page 155, which allows you to attach an auxiliary facing **5** to provide additional support to cut longer pieces. Select a suitable piece of smooth straight wood, drill two holes through it and attach it with screws **6** (Fig. 44).

Example:

- Drill 1/4" (6.35mm) dia. holes thru miter gauge.
- Drill 5/32" (4mm) dia. holes thru auxiliary facing board. Recommended board size: 3/4" (19mm) thick, 3" (76mm) high, and desired length.
- Attach with two round head wood screws No. 12x1-1/2" or M6x35mm **6**, not included (Fig. 44).

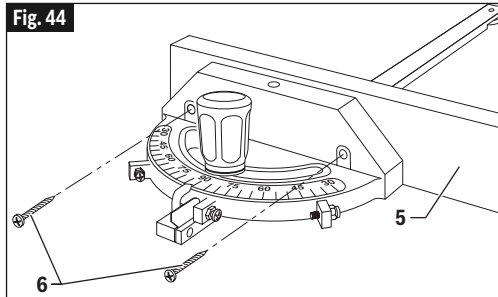

Be sure screws never protrude above outside surface of facing.

Be sure facing does not interfere with the proper operation of the saw blade guard.

NOTE: When bevel crosscutting, attach facing so that it extends to the right of the miter gauge and use the miter gauge in the groove to the right of the blade.

Using the Push Stick, Push Block, and Auxiliary Fence

When feeding the workpiece for a rip cut, use your hands only when they can be kept at least 6" (152mm) from the blade (Fig. 45). A push stick **22** (Fig. 46) or push block **PB** (Fig. 49) should be used any time the cut would cause your hands to be within 6" (152mm) of the blade.

Apply the feed force to the section of the work piece between the saw blade and the rip fence. Your other hand should be used only to guide the workpiece when it is at least 6" from the blade.

When using a push stick or push block, the trailing end of the board must be square. A push stick or block against an uneven end could slip off or push the work away from the rip fence.

When cutting a workpiece 1/8" (3.2mm) or less, use the auxiliary fence **AF** (Fig. 48) or the thin workpiece fence **25** (Fig. 1) mounted to the rip fence.

PUSH STICK

⚠ WARNING Never contact the spinning saw blade with the push stick. Contacting the spinning saw blade with the push stick may result in personal injury or property damage.

Only use the push stick **22** when the width of the rip cut is greater than 2" (50mm). When

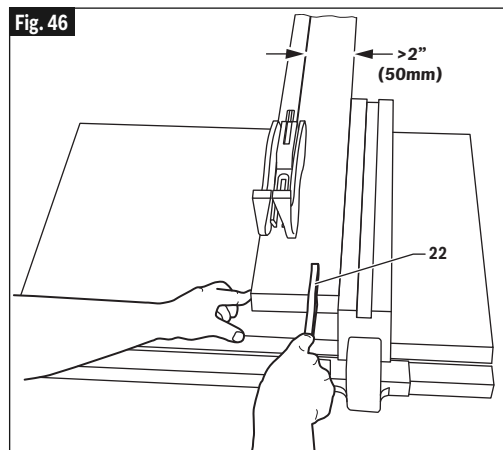
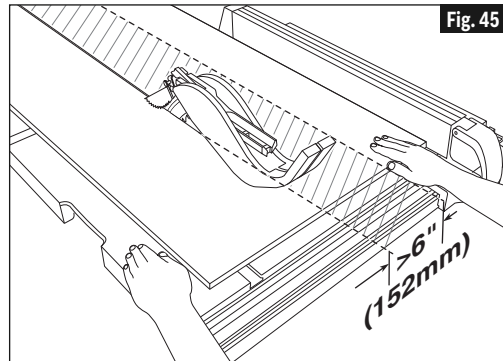

Basic Table Saw Operation

width of rip is less than 2" (50mm) the push stick cannot be used because the guard will interfere (Fig. 46).

Always position push stick and apply feed force parallel to the saw blade. Ensure that the push stick is positioned such that surface **A** is flat against the top of the workpiece, and surface **B** is fully engaged with the trailing end of the workpiece (Fig. 47). If a workpiece is shaped such that the push stick cannot be fully supported in this manner, an appropriate push block or jig should be used to support that workpiece.

PUSH BLOCK

When width of rip is narrower than 2" (50mm) the push stick cannot be used because the guard will interfere; use the auxiliary fence and push block.

Attach auxiliary fence **AF** to rip fence **18** with two "C" clamps (Fig. 48).

Feed the work piece by hand until the trailing end is approximately 1" (25mm) from the front edge of the table. Continue to feed using the push block **PB** on top of the auxiliary fence until the cut is complete (Fig. 49).

AUXILIARY AND THIN WORKPIECE FENCE

When cutting a workpiece with thickness of 1/8" (3.2mm) or less, it is important to prevent the workpiece from wedging between the table and bottom of the rip fence. Proper use of an auxiliary fence can eliminate gaps between the table and bottom of the rip fence. Use the auxiliary fence **AF** (Fig. 48) or the thin workpiece fence **25** (Fig. 1) and mount it to the rip fence **18** (Fig. 1) so there is no clearance between the bottom surface of the auxiliary fence and the table **2** (Fig. 1). Figure 49b illustrates the correct table and auxiliary fence position.

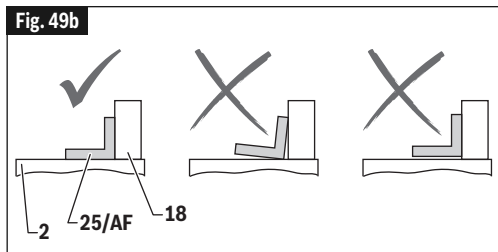
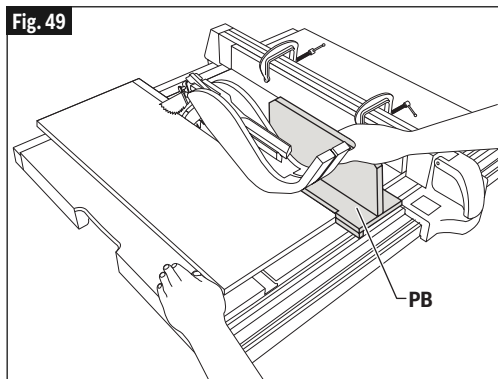
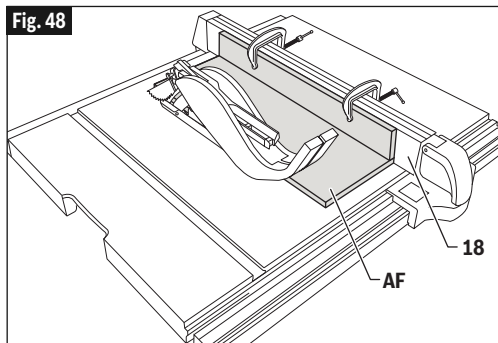
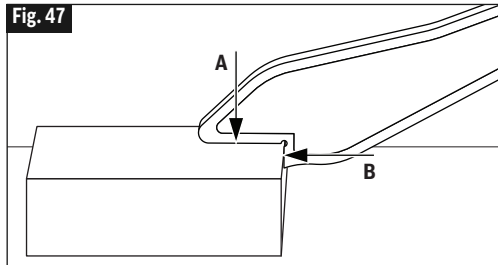

Basic Table Saw Operation

PRE-CUT LOCATOR

Allows you to mark and locate exactly where the blade will enter the workpiece.

Always make sure table saw is turned off and unplugged.

Set blade **1** at 90 degrees square to table.

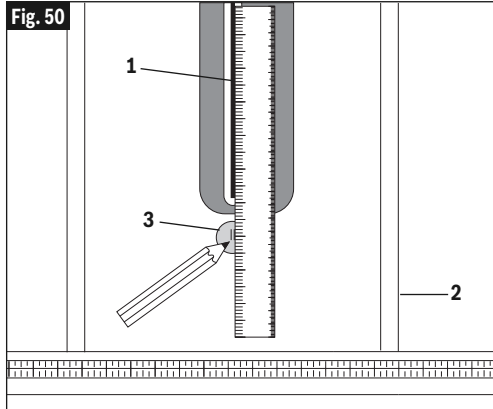

Using a straight edge and a soft pencil, place straight edge **2** against both sides of blade and mark lines on locator **3** (Fig. 50). These lines indicate the "path" of the cut (kerf) made by the blade.

When cutting the workpiece, line up mark on workpiece with the line on the disc (Fig. 51).

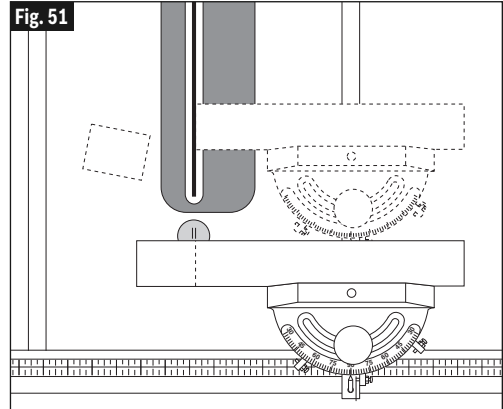

BLADE BEVEL CONTROL

Loosen blade bevel lock handle **1** counter-clockwise (Fig. 52), slide the elevation wheel **2** until pointer **3** is at desired angle and tighten blade tilt lock handle **1** clockwise.

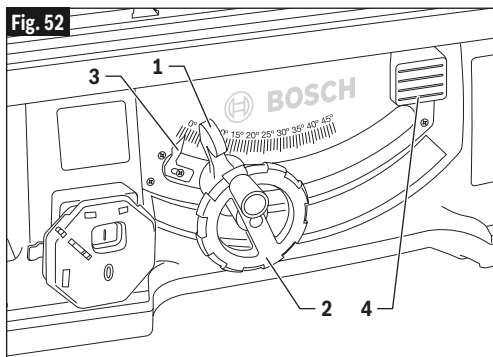

EXTENDING TABLE EXTENSION

To extend the table, raise the table extension lock handle **4** (Fig. 52) and slide table extension **5** to desired width (Fig. 53). To secure table setting, lower the lock handle **4**.

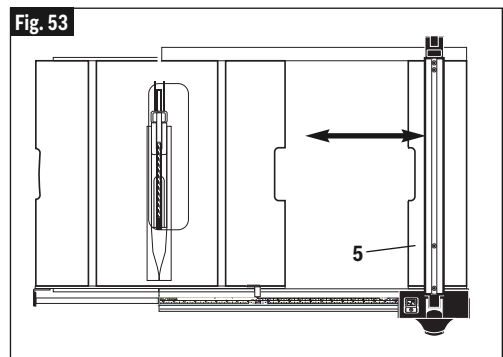

Basic Table Saw Operation

Using The Rip Fence

⚠ WARNING For your own safety, always observe the following safety precautions in addition to the safety instructions on Pages 3, 4, 5, 6, 7, and 8.

RIPPING, BEVEL RIPPING, RESAWING AND RABBETING are performed using the RIP FENCE together with the AUXILIARY FENCE / WORK SUPPORT, PUSH STICK OR PUSH BLOCK.

1. Never make these cuts FREEHAND (without using the rip fence or auxiliary devices when required) because the blade could bind in the cut and cause a KICKBACK.
2. Always lock the rip fence securely when in use.
3. Remove miter gauge from table during any operations which utilize the rip fence.
4. Make sure blade guard is installed for all thru-sawing type cuts. Replace the guard IMMEDIATELY following completion of resawing, rabbeting, dadoing or molding operations.

Frequently check the action of the ANTI-KICKBACK DEVICE by passing the workpiece alongside of the spreader while saw is OFF.

Pull the workpiece TOWARD you. If the PAWLS do not DIG into the workpiece and HOLD it ... the pawls must be REPLACED or SHARPENED. (See "Maintaining Your Table Saw" on Page 46).

5. Have blade extend approximately 1/8" (3.2mm) above top of workpiece. Additional blade exposure would increase the hazard potential.
6. Do not stand directly in front of the blade in case of a KICKBACK. Stand to either side of the blade.
7. Keep your hands clear of the blade and out of the path of the blade.
8. If the blade stalls or stops while cutting, TURN SWITCH OFF before attempting to free the blade.
9. Do not reach over or behind the blade to pull the workpiece through the cut ... to support long or heavy workpieces ...

to remove small cut-off pieces of material or FOR ANY OTHER REASON.

10. Do not pick up small pieces of cut-off material from the table. REMOVE them by pushing them OFF the table with a long stick. Otherwise they could be thrown back at you by the rear of the blade.
11. Do not remove small pieces of cut-off material that may become TRAPPED inside the blade guard while the saw is RUNNING. THIS COULD ENDANGER YOUR HANDS or cause a KICKBACK. Turn the saw OFF and disconnect power source. After the blade has stopped turning, lift the guard and remove the piece.
12. If workpiece is warped, place the CONCAVE side DOWN. This will prevent it from rocking while it is being ripped.
13. When "WIDTH OF RIP" is 6" (152mm) and WIDER use your RIGHT hand to feed the workpiece, use LEFT hand ONLY to guide the workpiece ... do not FEED the workpiece with the left hand (Fig. 45).

When "WIDTH OF RIP" is 2" to 6" (50 to 152mm) wide USE THE PUSH STICK **22** to feed the work (Fig. 46).

When WIDTH OF RIP is NARROWER than 2" (50mm) the Push Stick CANNOT be used because the guard will interfere ... USE the AUXILIARY FENCE, and PUSH BLOCK.

RIPPING

RIPPING is known as cutting a piece of wood with the grain, or lengthwise. This is done using the rip fence. Position the rip fence to the desired WIDTH OF RIP and lock in place. Before starting to rip, be sure:

- A. Rip Fence is parallel to sawblade.
- B. Riving knife is properly aligned with sawblade.
- C. Anti-kickback Device is functioning properly.

When ripping LONG BOARDS or LARGE PANELS, always use a work support (Fig. 45). The Bosch table saw outfeed support table kit (TS1008, TS1016) is an ideal accessory to use for this application.

BEVEL RIPPING

When bevel ripping material 6" (152mm) or

Basic Table Saw Operation

narrower, use rip fence on the right side of the blade **ONLY**. This will provide more space between the rip fence and the sawblade for use of a Push Stick. If the rip fence is mounted to the left, the sawblade guard may interfere with proper use of a Push Stick.

Attach auxiliary fence **AF** to rip fence with two "C" clamps (Fig. 48).

Feed the workpiece by hand until the end is approx. 1" (25mm) from the front edge of the table. Continue to feed using the **PUSH BLOCK 3** on top of auxiliary fence **UNTIL THE CUT IS COMPLETE** (Fig. 49).

USING THE RIP FENCE POINTER WHEN TABLE IS NOT EXTENDED

The rip fence pointer shows the distance from the blade to rip fence through a convenient viewing and magnifying window.

Align rip fence pointer **4** with lower portion of scale **5**. The lower scale can be used for widths up to 14.5 inches [368mm] (Fig. 54).

USING THE TABLE POINTER WHEN TABLE IS EXTENDED

Move the rip fence to the 14.5" mark and lock in place. The upper portion of scale **6** is used for rip cut 14.5 to 30 inches (368 to 762mm). Align table pointer **7** with upper portion of scale **6** (Fig. 54).

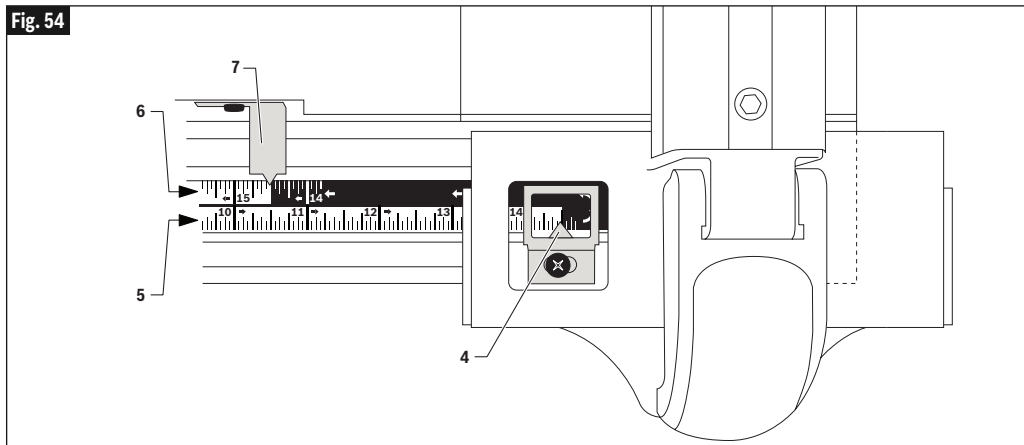

Basic Table Saw Operation

Using The Miter Gauge

⚠ WARNING For your own safety, always observe the following safety precautions in addition to the safety instructions on Pages 3, 4, 5, 6, 7, and 8.

CROSSCUTTING, MITER CUTTING, BEVEL CUTTING, COMPOUND MITER CUTTING and when RABBETING across the end of a narrow workpiece, the MITER GAUGE is used.

Never make these cuts freehand (without using the miter gauge or other auxiliary devices) because the blade could bind in the cut and cause a KICKBACK or cause your fingers or hand to slip into the blade.

Always lock the miter gauge securely when in use.

Remove rip fence from table during any operations which utilize the miter gauge.

The miter includes a “T” groove disk **5** for easy insertion into table groove and quicker removal from the table (Fig. 55).

When cross cutting and the blade set at 90° or 45° to the table, the miter gauge can be used in either slot on the table. When cross cutting and the blade is tilted, use slot on right side of table where the blade is tilted away from your hands and miter gauge.

ADJUSTING THE MITER ANGLE:

Loosen lock knob **1** and set the miter gauge body **2** so the pointer **3** is at desired angle, then tighten lock knob **1** (Fig. 55).

The miter gauge body **2** will stop at 90° and both right and left 45°. To rotate the miter gauge body **2** beyond these points, the stop plate **4** must be flipped out of the way.

CROSSCUTTING

CROSSCUTTING is known as cutting wood across the grain, at 90°, or square with both the edge and the flat side of the wood. This is done with the miter gauge set at 90° (Fig. 56).

Make sure blade guard is installed for all “thru-sawing” operations (when sawblade cuts entirely thru the thickness of the workpiece). Replace guard IMMEDIATELY after completion of dadoing, molding or rabbeting cuts.

Have blade extend approximately 1/8” (3.2mm) above top of workpiece. Additional blade exposure would increase the hazard potential.

Fig. 55

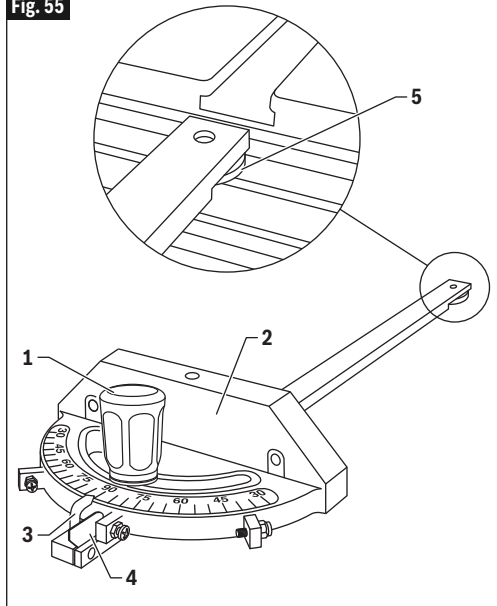
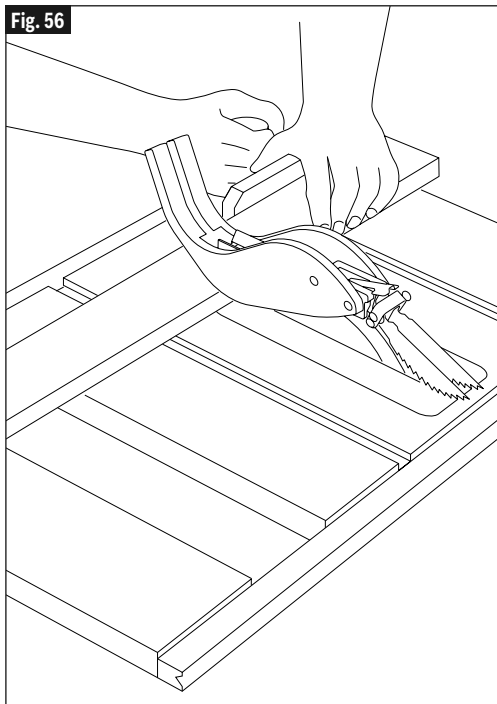

Fig. 56



Basic Table Saw Operation

Do not stand directly in front of the blade in case of a THROWBACK. Stand to either side of the blade.

Keep your hands clear of the blade and out of the path of the blade.

If blade stalls or stops while cutting, TURN SWITCH OFF before attempting to free the blade.

Do not reach over or behind the blade to pull the workpiece through the cut ... to support long or heavy workpieces ... to remove cut-off pieces of material or FOR ANY OTHER REASON.

Do not pick up small pieces of cut-off material from the table. REMOVE them by pushing them OFF the table with a long stick. Otherwise they could be thrown back at you by the rear of the blade.

Do not remove small pieces of cut-off material that are close to or may become TRAPPED inside the blade guard while the saw is RUNNING. THIS COULD ENDANGER YOUR HANDS or cause a KICKBACK. Turn the saw OFF. After the blade has stopped turning, lift the guard and remove the piece.

If workpiece is warped, place the CONCAVE side DOWN. This will help prevent it from rocking while it is being cut.

The graduations on the miter gauge provide accuracy for average woodworking. In some cases where extreme accuracy is required, when making angle cuts, for example, make a trial cut and then recheck it with an accurate square or protractor.

If necessary, the miter gauge head can be swiveled slightly to compensate for any inaccuracy.

TIP: The space between the miter gauge bar and the groove in the table is held to a minimum during manufacturing. For maximum accuracy when using the miter gauge, always “favor” one side of the groove in the table. In other words, don’t move the miter gauge from side to side while cutting but keep one side of the bar riding against one side of the groove.

TIP: Glue a piece of sandpaper **1** to the face of the miter gauge head. This will help prevent the workpiece from “creeping” while it is being cut.

The miter gauge may be used in either of the grooves in the table. Make sure it is locked.

When using the miter gauge in the LEFT hand groove, hold the workpiece firmly against gauge head with your left hand, and grip the

lock knob with your right hand.

When using the RIGHT hand groove, hold the workpiece with your right hand and the lock knob with your left hand.

REPETITIVE CROSSCUTTING

REPETITIVE CROSSCUTTING is known as cutting a quantity of pieces the same length without having to mark each piece. When making repetitive cuts from a long workpiece, make sure it is supported – see Fig. 57.

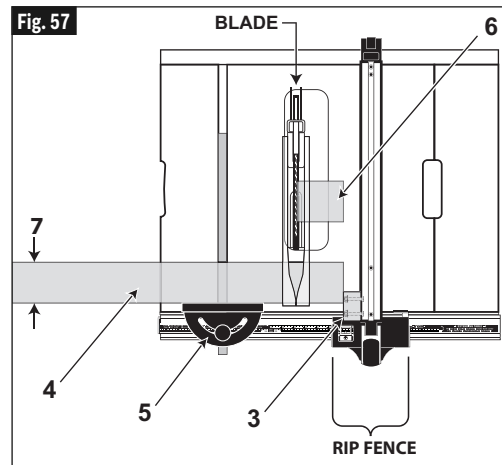

Never use the rip fence as a direct length stop because the cutoff piece could bind between the rip fence and the blade causing kickback.

When attaching the facing block, make sure the block is well in front of the sawblade, because the cutoff piece could bind between the rip fence and the blade causing kickback.

MAKING THE REPETITIVE CROSSCUT

- A. When making repetitive cuts, securely attach a wood facing block to the rip fence as shown. The T-slot in the rip fence allows for attachment - see Figure 57.
- B. Slide the rip fence (with the facing block) to a position which gives you the length of board that you want to repeat. Lock rip fence in position. Note: If you are using the scale on the saws front rail during the set-up, be sure move the rip fence an additional 1-1/2 inches (38mm) to compensate for the thickness of the facing block.

Basic Table Saw Operation

- C. Slide the workpiece **4** along the miter gauge **5** until it touches the facing block **3**. Hold workpiece securely.
- D. Make a “dry run” (practice) – with the saw unplugged, move the miter gauge and workpiece along the facing block until it touches the idle blade (blade is set 1/4 inch (6mm) higher than workpiece) – **Note:** The workpiece **MUST** be off the facing block **BEFORE** it contacts the blade. Crosscutting capacity **7** for these cuts is 7-1/2 inches (191mm) with a 3/4" (19mm) workpiece or 6-3/4 inches (171mm) with a 1-1/2" (38mm) workpiece. If “dry run” is successful, go to the next step.
- E. Attach saw to power source, turn saw on, and make the cut. Turn the saw off and remove the cutoff piece **6** after the blade has stopped and before cutting the next piece.

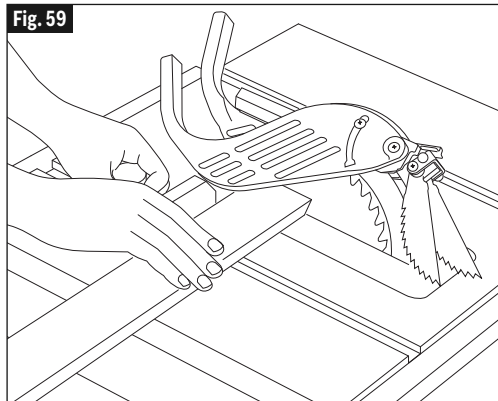
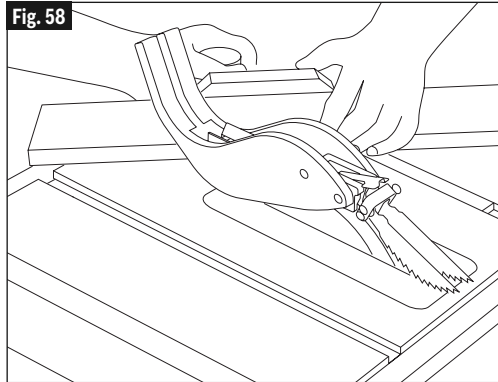

Use the Miter Gauge in the groove to the RIGHT or the LEFT of the blade.

MITER CUTTING

MITER CUTTING is known as cutting wood at an angle other than 90° with the edge of the wood. Follow the same procedure as you would for crosscutting (Fig. 58).

Adjust the miter gauge to the desired angle, and lock it.

The miter gauge may be used in either of the grooves in the table.

When using the miter gauge in the LEFT hand groove, hold the workpiece firmly against the miter gauge head with your left hand, and grip the lock knob with your right hand.

When using the RIGHT hand groove, hold the workpiece with your right hand and the lock knob with your left hand.

BEVEL CROSSCUTTING

BEVEL CROSSCUTTING is the same as crosscutting except that the wood is also cut at a bevel angle (Fig. 59) ... other than 90° with the flat side of the wood.

Adjust the blade to the desired angle.

COMPOUND MITER CUTTING

COMPOUND MITER CUTTING is a combination of miter cutting and bevel crosscutting. The cut is made at an angle other than 90° to both the edge and the flat side of the wood (Fig. 59).

Adjust the miter gauge and the blade to the desired angle and make sure miter gauge is locked.

Basic Table Saw Operation

Non-Thru Cutting

Add 8" (203mm) high flat facing board to the rip fence, the full length of the rip fence (Fig. 60).

Use featherboards for all "Non Thru-Sawing" operations (when sawblade guard must be removed). Featherboards **1** are used to keep the work in contact with the rip fence and table as shown, and to stop kickbacks.

Mount featherboards **1** to rip fence and table as shown, so that leading edges of featherboards will support workpiece until cut is complete, and the workpiece has been pushed completely past the cutter (sawblade, dado head, molding head, etc.) with a push stick **22**, as in ripping.

Before starting the operation (switch saw "OFF" and set cutter below table surface):

- A. Install featherboards so they exert pressure on the workpiece; be positive they are securely attached.
- B. Make sure by trial that the featherboards will stop a kickback if one should occur.

Featherboards are not employed during non thru-sawing operations when using the miter gauge.

Replace the smart guard system as soon as the non thru-sawing operation is complete.

RABBETING

RABBETING is known as cutting out a section of the corner of a piece of material, across an end or along an edge (Fig. 61).

Making a RABBET requires cuts which do not go all the way through the material. Therefore the smart guard system must be removed.

- A. Remove blade guard.
- B. For rabbeting along an edge (long way of workpiece) as shown, add facing to rip fence approximately as high as the workpiece is wide. Adjust rip fence and blade to required dimensions; then make first cut with board flat on table, follow set-up Fig. 60. Make second cut with workpiece on edge. Follow all precautions, safety instructions, and operation instructions as for ripping or rip type operations, including featherboards and push stick, etc.
- C. For rabbeting across an end, for work-

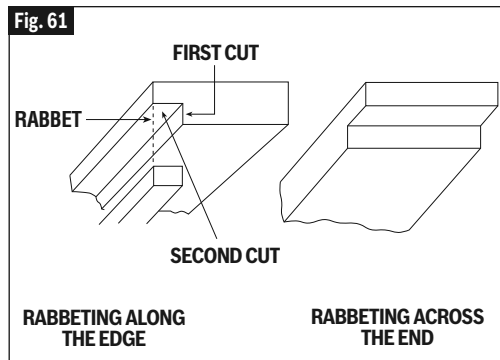
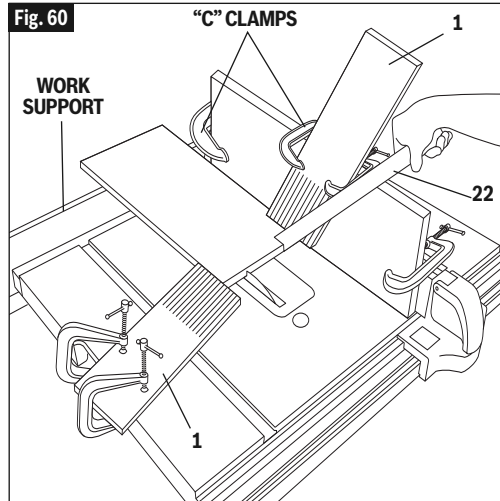

piece 10-1/2" (267mm) and narrower make the rabbet cut with the board flat on the table. Using the miter gauge fitted with a facing, follow the same procedures and instructions for crosscutting making successive cuts across the width of the workpiece to obtain the desired width of cut. DO NOT use the rip fence for rabbeting across the end.

- D. INSTALL SMART GUARD SYSTEM IMMEDIATELY UPON COMPLETION OF RABBETING OPERATION.

Rabbet cuts can also be made in one pass of the workpiece over the cutter using the dado head or molding head.

Basic Table Saw Operation

DADO CUTTING

Instructions for operating the saw with dado and molding head sets are contained in the booklet furnished with these accessories.

ALWAYS USE AN APPROPRIATE BOSCH TABLE INSERT AND WASHERS LISTED UNDER RECOMMENDED ACCESSORIES (see page 48).

ALWAYS PLACE THE BLADE WASHERS IN THE ORIGINAL POSITIONS WHEN YOU ARE FINISHED DADO OR MOLDING CUTTING.

INSTALLING A DADO SET

⚠ WARNING To reduce the risk of injury, always disconnect plug from power source before changing blades.

⚠ WARNING To reduce the risk of injury, always use the Bosch Dado Blade Table Insert No.TS1007 (comes with a dado accessory washer). Never make dado cuts without this insert. Do not use dado sets larger than 8" (203mm) diameter. Never set dado cutters to any bevel angle other than the vertical 0° angle. Follow all warnings and instructions shown here and those that accompany your dado set. Failure to comply with these warnings may result in serious bodily injuries.

⚠ WARNING To reduce the risk of injury, do not use dado sets larger than 8 inches (203mm) in diameter. The saw is not designed to accept larger sized dados.

A dado set is an accessory system used to make non-thru grooves or lap cuts on work pieces. These tools are commonly used in fur-

niture and cabinet building. After work pieces have been properly dado cut, they can be tightly joined together. The 4100XC table saw can accommodate dado cutting up to 13/16" (20.6mm) wide in a single pass.

USING STACKED DADO SETS

⚠ WARNING To reduce the risk of injury or property damage, read and follow all Operation/Safety Instructions included with the dado set before use.

⚠ WARNING To reduce the risk of injury, never use a single dado blade for normal saw thru-cutting. Never use chippers without both outside cutters. Read and follow all Operation/Safety Instructions included with the dado set.

⚠ WARNING To reduce the risk of injury, never pass your hands over the cutting dado blades. Dado cuts are non-thru (blind) cuts. Many times the cutters cannot be seen during cutting. See page 41 for instructions on Non Thru-sawing.

⚠ WARNING To reduce the risk of injury, never make free-hand cuts. The work piece must be held against the saw's rip fence or miter gauge as it is being fed. Whenever possible, use push sticks and push blocks for cutting (see page 33). Always use feather boards, attached to the table or rip fence, when rip cutting (see page 41). When cross cutting, firmly hold work piece against the miter gauge (see page 38).

NOTE: These instructions apply when using most standard stacked dado sets. Do not use

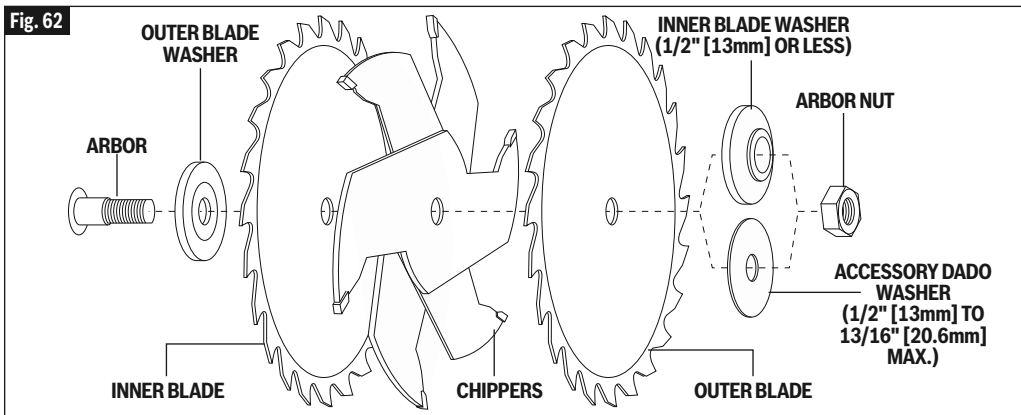

Basic Table Saw Operation

dado set if manufacturer instructions differ from the ones provided below.

1. Disconnect plug from power source.
 2. Remove the barrier guard assembly and anti-kickback device (see page 17 and 18). Lower and lock the Riving Knife in its lowest position.
 3. Remove standard table insert plate. Raise saw blade to maximum height.
 4. Remove the arbor nut, then outer washer, saw blade, and inner blade washer (see page 20). Note: For only dado cutting, the washers must be installed differently (Fig. 63).
 5. Installing a dado stack (Fig. 62)
 - A. Place the (flat) outer washer back onto the arbor shaft. For dado cutting, this will serve as the inner washer.
 - B. Place the desired parts of the dado set onto the arbor shaft.
 - C. Place the supplied washer from the Dado Accessory Kit (TS1007) onto the outside of the dado stack.
 - D. Replace and tighten the arbor nut onto the arbor shaft (Fig. 63).
 6. Placing dado blades and chippers: (see Fig. 62)
 - For 1/4" (6mm) wide cuts, place the two outside dado blades (cutters) on the shaft. The two dado outside blades may be different, check for information on the blade and the manufacturer's instructions for proper installation.
 - For wider cuts (up to 13/16" [20.6mm] maximum), chipper blades and spacers can be placed only between the outside blades (cutters).
- NOTE:** The arbor nut must be fully engaged on shaft threads. If the stacked width is more than 1/2" (13mm), do not use the table saw's inner washer. Instead, use the accessory dado washer (included with Bosch Dado Table Insert TS1007). With this saw, do not exceed a stacked width greater than 13/16" (20.6mm).
7. Lower the blades below the table top and insert the Bosch Dado Table Insert TS1007 (Fig. 64). Raise the cutters to the desired depth of cut (above the insert). Check that the tool is not plugged

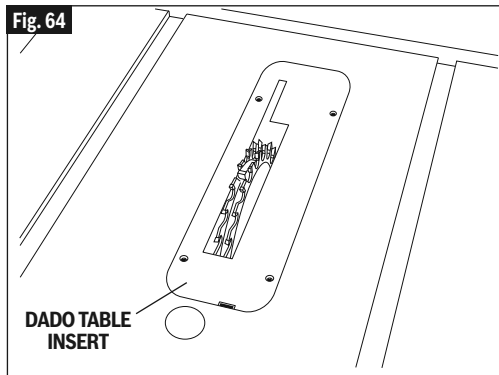
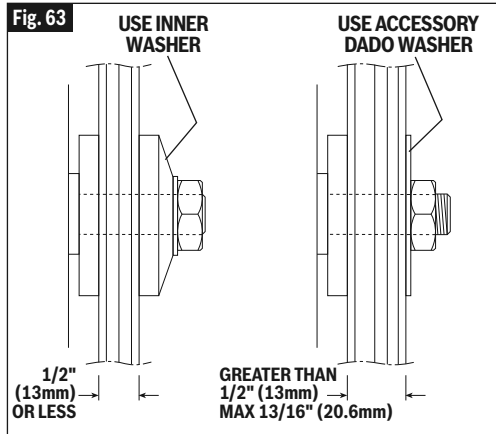

into a power source; then carefully rotate the cutters by hand to make sure all components are tightly held and no interferences exist.

8. Plug saw into power source. Using scrap wood, make practice dado cuts and adjust height accordingly.

NOTE: Because dado cuts are non-thru cuts, the miter gauge can be used with the rip fence locked in place. This is helpful when making repeat dado cross-cuts from the ends of more than one work piece. Each piece is held against the miter gauge and its end slides along the rip fence at a preset distance.

Depending on the final depth of cut and/or the density of the material, it may be required to make multiple cuts starting with small depths of 1/4" (6mm) to 1/2" (13mm) and progressing to final depth. When performing extensive repetitive dado cutting, periodically check the work pieces to see that the depth

Basic Table Saw Operation

of cut is maintained.

RETURNING SAW TO NORMAL THRU-CUTTING

After completing your dado cutting, be sure to return the inner and outer washers to the original positions (see page 20 for details). It is important that the original equipment washers are in the proper positions so that the saw blade always aligns with the permanently installed riving knife (Fig. 63).

ADJUSTABLE OR WOBBLE DADO SETS

⚠ WARNING To reduce the risk of injury, do not use adjustable or “wobble” dado sets on this saw. Adjustable dado sets can be easily set to positions that may interfere with working components of this saw.

INSTALLING A MOLDING HEAD SET

⚠ WARNING To reduce the risk of injury, always disconnect plug from power source before changing blades.

⚠ WARNING To reduce the risk of injury, always use the Bosch Molding Table Insert No.TS1009. Never make molding head cuts without this insert. Do not use molding head sets larger than 7" (178mm) diameter and with cutters wider than 1" (25mm). Never set molding cutters to any bevel angle other than the vertical 0° angle. Follow all warnings and instructions shown here and those that accompany your molding head set. Failure to comply with these warnings may result in serious bodily injuries.

⚠ WARNING To reduce the risk of injury, never pass your hands over the cutting molding head cutters. Molding cuts are non-thru (blind) cuts. Many times the cutters can not be seen during cutting. See page 41 for instructions on non-thru sawing. The work piece must be held against the saw's rip fence as it is being fed. An auxiliary fence should be attached to the saw's rip fence (see page 34). Never make freehand cuts. Whenever possible, use push sticks and push blocks for molding cutting (see page 33). Use feather boards and hold-downs, attached to the table or rip fence (See page 41). **IMPORTANT:** Follow all instructions and warnings that come with your

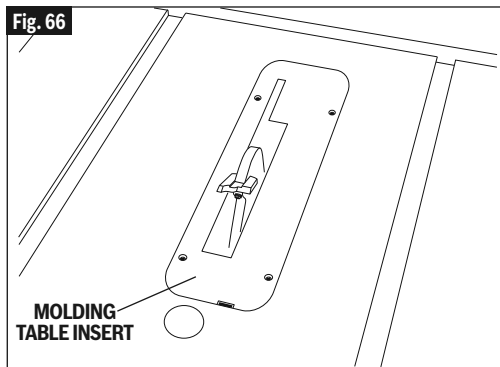
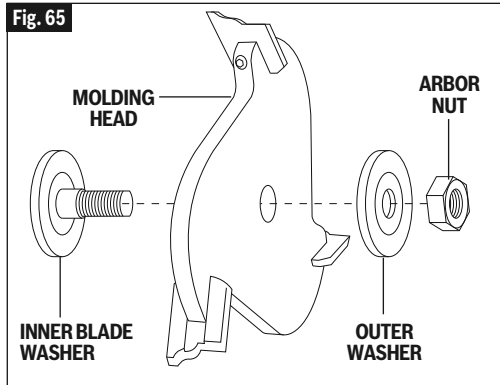

molding head set.

A Molding Head Set may be used to add a variety of decorative edges to a wood work piece. These edges are commonly seen on trim moldings and furniture.

NOTE: Leave the inner washer in its original sawing position. Install molding head, then outer washer, and then arbor nut. Check that all cutters and the arbor nut are securely tightened. Some molding head sets come with an additional thick washer/spacer; this part is not used on the 4100XC table saw.

- Disconnect plug from power source. Raise saw blade to maximum height.
- Remove the barrier guard assembly and anti-kickback device (see page 17 and 18). Lower and lock the riving knife in its lowest position.
- Remove standard table insert plate.
- Remove the arbor nut and only the outer blade washer and saw blade (see

Basic Table Saw Operation

page 20). **NOTE:** Leave inner blade washer on arbor shaft.

- E. Place molding head against inner washer (with cutters facing to front of saw). Then place on the outer washer and tighten arbor nut on arbor shaft.
- F. Lower the cutters below the table top and insert the Bosch Molding Table Insert TS1009 (Fig. 66). Raise the cutters to the desired depth of cut (above the insert). Check that the tool is not plugged into a power source; then carefully rotate the cutters by hand to make sure all components are tightly held and no interferences exist.
- G. Plug saw into power source. Using scrap wood, make practice molding cuts and adjust height accordingly.

RETURNING SAW TO NORMAL THRU-CUTTING

After completing your molding cutting, be sure to return the inner and outer washers to the original positions (see page 20 for details). It is important that the original equip-

ment washers are in the proper positions so that the saw blade always aligns with the permanently installed riving knife.

Special Cutting Techniques

⚠ WARNING Do not attempt to perform cuts not covered in this manual unless you are thoroughly familiar with appropriate procedures and fixturing.

This table saw is a highly versatile tool, capable of performing a wide range of highly specialized cuts that cannot be covered in this manual.

See your local library for books on woodworking techniques, such as: *The Complete Book of Stationary Power Tool Techniques* by R.J. De Christoforo or *Table Saw Techniques* by R. Cliffe.

Attachments

⚠ WARNING Use only recommended attachments. Follow instructions that accompany attachments. Use of improper attachments may cause hazards.

Item	Cat. No.
Rear Outfeed Support	TS1016
Left Side Support	TS1008
Dust bag	TS1004
Zero Clearance Insert	TS1005
Dado Insert Set	TS1007
Molding Insert	TS1009
Pusher Guide System	TS1010
Gravity-Rise Wheeled Table Saw Stand	TS2100
Vacuum hose adapter	VAC004

Troubleshooting

⚠ WARNING Turn switch “OFF” and always remove plug from the power source before troubleshooting.

Problem	Cause	Corrective Action
Saw will not start	Power cord is not plugged in.	Plug saw in.
	Fuse or circuit breaker tripped.	Replace fuse or reset tripped circuit breaker.
	Cord damaged.	Have cord replaced by an Authorized Bosch Service Center or Service Station.
	Burned out switch.	Have switch replaced by an Authorized Bosch Service Center or Service Station.
Blade does not come up to speed	Extension cord too light or too long.	Replace with adequate cord.
	Low house voltage.	Contact your electric company.
Excessive vibration	Failure to tighten tilt lock handle.	See “Getting To Know Your Table Saw” section, (Pages 12–13).
	Blade out of balance.	Discard Blade and use different blade.
	Saw not mounted securely to stand or workbench.	Tighten all mounting hardware, See “Mounting the Table Saw” section, (Page 23).
	Arbor Nut not tight.	See “Assembly” section, “Changing The Blade” (Page 19).
Cannot make square cut when crosscutting	Miter Gauge not adjusted properly.	See “Adjustments” section, “Miter Gauge Adjustment” (Page 24).
Cut binds, burns, stalls motor when ripping	Dull blade with improper tooth set.	Sharpen or replace blade.
	Warped board.	Make sure concave or hollow side is facing “DOWN” feed slowly.
	Rip fence not parallel to blade.	See “Adjustments” section “Aligning Rip Fence” (Page 25).
	Spreader out of alignment.	See “Assembly” section, “Attaching the Smart Guard System” (Page 18).
Cut not true at 90° or 45° positions	Alignment screws not adjusted properly.	See “Adjustments” section, “Adjusting Blade Parallel to Miter Gauge Slots” (Page 23).
Tilt lock handle elevation wheel hard to move	Blade tilt lock handle not loosened when making tilt adjustment.	See “Getting To Know Your Table Saw” section, “Blade Tilt Lock Knob” (Pages 12–13).
	Saw dust on depth screw threads.	See “Maintaining Your Table Saw” section, “Lubrication” (Page 46).

IMPORTANT
Read Before Using

IMPORTANT
Lire avant usage

IMPORTANTE
Leer antes de usar



Operating / Safety Instructions STAND

GTA47W

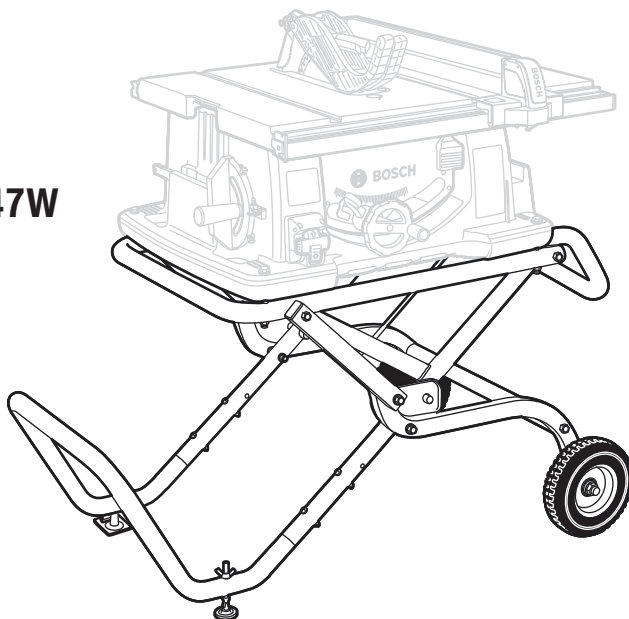

BOSCH

Call Toll Free for Consumer Information and Service Locations

Pour obtenir des informations et les adresses de nos centres de service après-vente, appelez ce numéro gratuit

Llame gratis para obtener información para el consumidor y ubicaciones de servicio

1-877-BOSCH99 (1-877-267-2499) www.boschtools.com





For English Version
See page 2

Version française
Voir page 11

Versión en español
Ver la página 20

Safety Symbols

The definitions below describe the level of severity for each signal word. Please read the manual and pay attention to these symbols.

	<p>This is the safety alert symbol. It is used to alert you to potential personal injury hazards. Obey all safety messages that follow this symbol to avoid possible injury or death.</p>
	<p>DANGER indicates a hazardous situation which, if not avoided, will result in death or serious injury.</p>
	<p>WARNING indicates a hazardous situation which, if not avoided, could result in death or serious injury.</p>
	<p>CAUTION indicates a hazardous situation which, if not avoided, could result in minor or moderate injury.</p>

Safety Instructions

WARNING Read all instructions. Failure to follow all instructions listed below may result in serious personal injury.

Fully assemble and tighten all the fasteners required for this stand. Periodically check that all fasteners are attached and adjusted according to the assembly instructions included in this manual. A loose stand is unstable and may shift in use and cause serious injury.

Turn tool switch off and disconnect power before mounting to the stand. Unintended startup during assembly can cause injury.

Before operating make sure the entire unit is placed on a solid, flat, level surface. Serious injury could occur if tool is unstable and tips.

Never stand on tool or its stand or use as ladder or scaffolding. Serious injury could occur if the tool is tipped or the cutting tool is accidentally contacted. Do not store materials on or near the tool such that it is necessary to stand on the tool or its stand to reach them.

Use only Bosch replacement parts. Any others may create a hazard.

Pre-Assembly

You have purchased a Bosch Table Saw Stand GTA47W. Designed for job site use. This unit sets up and folds quickly, and is easily loaded or unloaded by one person into a truck.

BEFORE YOU ASSEMBLE THIS TABLE SAW STAND:

Sort out and account for all parts to make sure that you have all necessary materials to assemble your stand. Do not discard packing material until all parts are accounted for.

TOOLS REQUIRED:

- Phillips screwdriver,
- Two (2) 10 mm open end wrenches,
- Two (2) 13 mm open end wrenches,
- One (1) 24mm (or 15/16") open end wrench;

or you can use two (2) adjustable wrenches (one should have at least 1" capacity).

Table Saw Stand Parts		
Item	Qty.	Part Description
A	1	Upper Cross Bar
B	1	Lower Cross Bar
C	1	Kick Bar
D	1	Right Linkage Bar ("R")
E	1	Left Linkage Bar ("L")
F	1	Top Tube Bar
G	1	Right Wheel Bar ("R")
H	1	Left Wheel Bar ("L")
I	2	Wheel

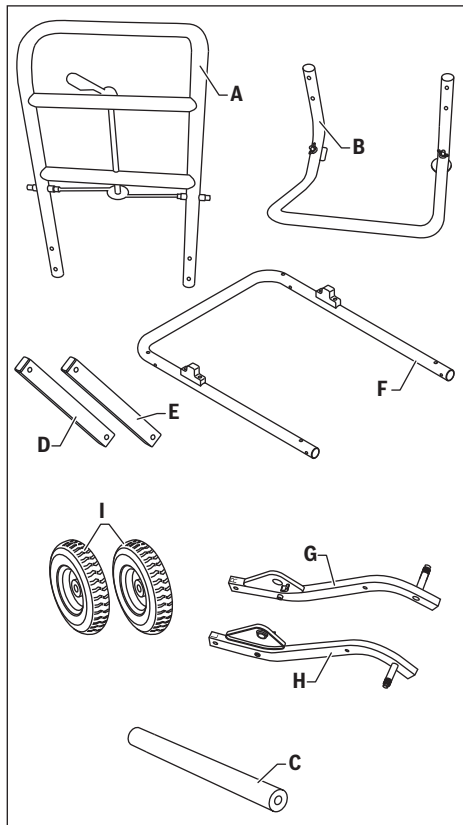

ACTUAL SIZE

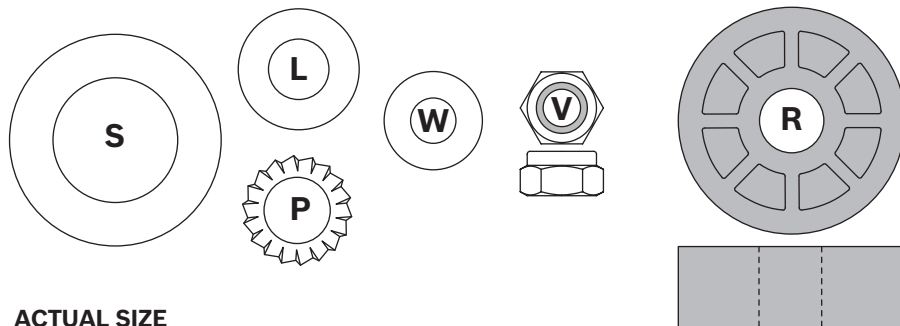
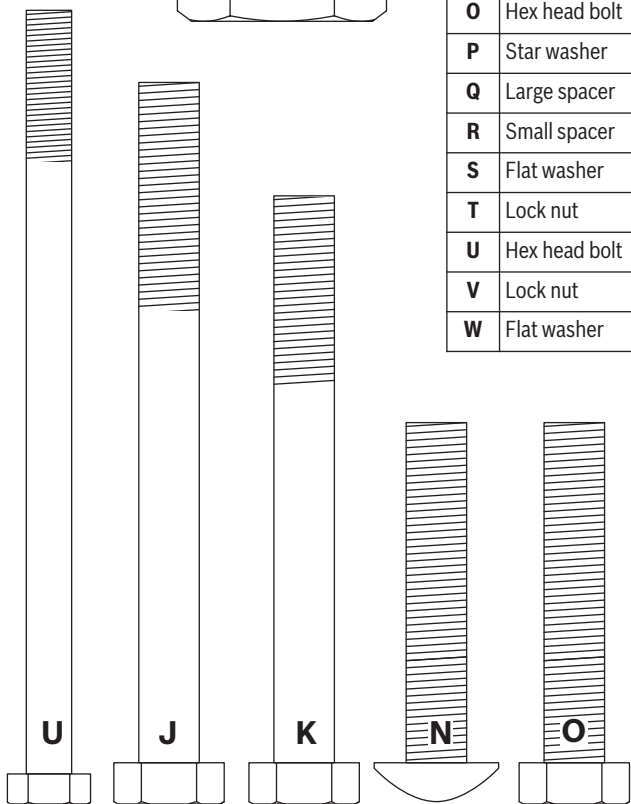
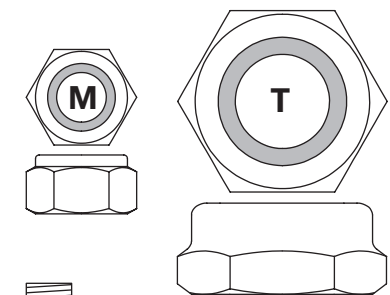

ACTUAL SIZE

GTA47W Stand Assembly Hardware
(packaged in one bag)

Item	Part Description	Specs.	Qty.
J	Hex head bolt	M8 x 90mm	4
K	Hex head bolt	M8 x 75mm	4
L	Flat washer	∅8 x ∅16 x 1.5mm	18
M	Lock nut	M8	12
N	Phillips head screw	M8 x 45mm	4
O	Hex head bolt	M8 x 45mm	2
P	Star washer	M8	2
Q	Large spacer	∅30 x 17mm	2
R	Small spacer	∅30 x 11mm	4
S	Flat washer	∅16.5 x ∅28 x 2mm	2
T	Lock nut	M16	2
U	Hex head bolt	M6 x 100mm	4
V	Lock nut	M6	4
W	Flat washer	∅6 x ∅13 x 1.5mm	8

Assembly

Step 1. Attach Upper and Lower Cross Bars

1. Position lower cross bar **B** on a flat surface as shown in figure 1.
2. Insert ends of lower cross bar **B** into the upper cross bar **A** and align the holes of both bars.
3. Insert four (4) phillips head screws **N** through the holes of the upper and lower cross bars. Using phillips screwdriver and 13mm wrench securely tighten with four (4) M8 lock nuts **M** as shown.

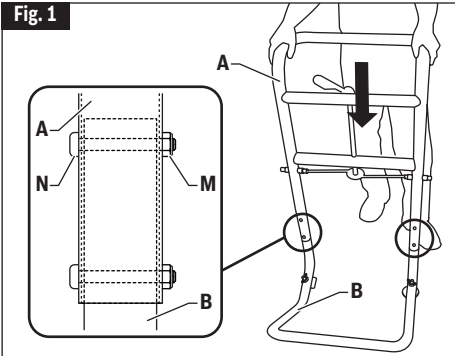

Step 2. Attaching wheels

1. Mount the wheel **I** on the axle of the wheel bar **H** (Fig. 2).
2. Place one (1) flat washer **S** on the threaded end of the wheel axle. Thread the lock nut **T** on the threaded end of the wheel axle by hand (Fig. 2).
3. Using 24mm wrench tighten the lock **T** until washer **S** does not move freely. Spin the wheel to check tightness. If the wheel doesn't turn freely, loosen the nut by 1/8 to 1/4 of a turn.
4. Repeat the same steps with the other wheel bar **G**.

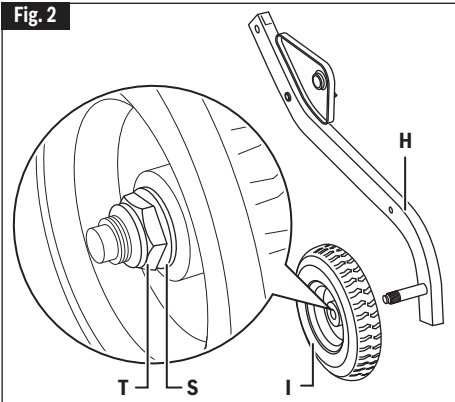

Step 3. Left and Right Linkage Bar/Wheel Assemblies

1. Locate the left linkage bar **E** and left wheel bar **H**. Note the "R" stickers on each component.
2. Place one (1) flat washer **L** on one (1) bolt **K**. Line up the "R" stickers and insert the bolt, first, through the wheel assembly **H**, then through the large spacer **Q**, and then through the left linkage bar **E** as shown in figure 3.
3. Place another one (1) flat washer **L** on bolt **K**. Using two 13mm wrenches tighten with one (1) lock nut **M** until all the parts cannot move freely. Then loosen the nut by 1/8 to 1/4 turn.

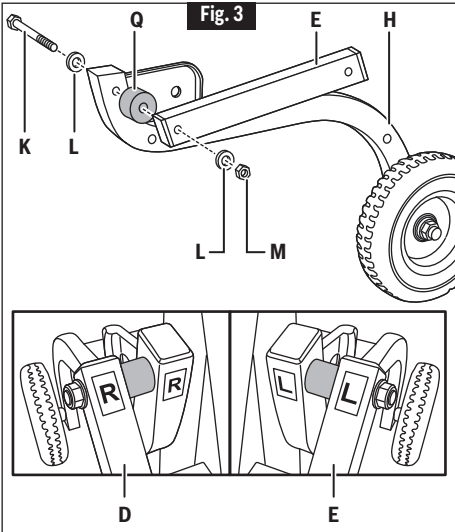

bar **D** and right wheel assembly **G**. Note the "R" sticker on each component.

4. Repeat steps 1-3 using right linkage

Assembly

Step 4. Attach Linkage Bar/Wheel Assemblies

1. Locate the right linkage bar **D**/wheel assembly **G** and position on right side of upper/lower cross bar assembly **A** as shown in figure 4. **Note:** Wheel should face outward from stand.
2. Place one (1) flat washer **L** onto one (1) bolt **J** and insert through right wheel assembly **G**.
3. Place another (1) flat washer **L** on bolt between wheel assembly **G** and upper/lower cross bar assembly **A**.
4. Insert bolt through upper/lower cross bar assembly **A**, place one (1) flat washer **L**. Using two 13mm wrenches tighten with one (1) lock nut **M** until all the parts can not move freely. Then loosen the nut by 1/8 to 1/4 turn. **Note:** Do not over-tighten lock nut - these parts need to freely rotate for stand to operate properly.
5. Repeat procedure on left side.

Step 5. Attach Kick Bar

1. Locate the kick bar **C** and position it between the left and right wheel assemblies **H** and **G** as shown in figure 5.

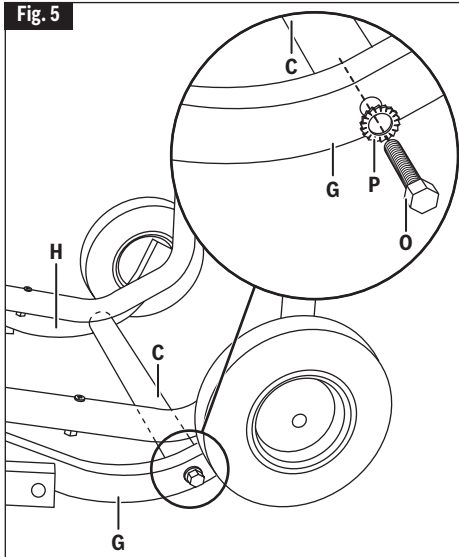
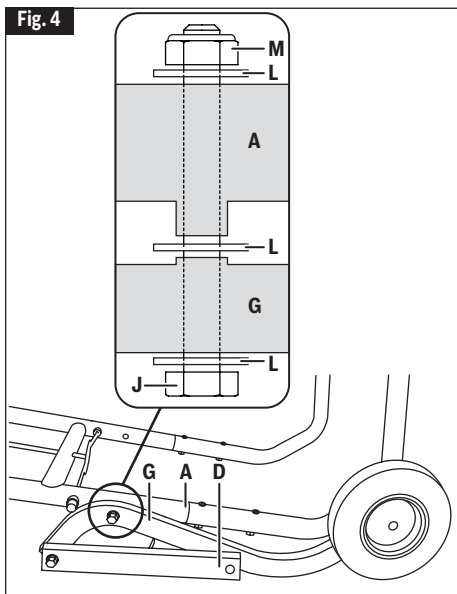

2. Place one (1) star washer **P** onto one (1) hex head bolt **O**. Insert bolt through the wheel assembly and thread it into the kick bar **C** and, using 13mm wrench, tighten down to the point when the star washer **P** cannot move freely. Then tighten securely by turning bolt an additional 3/4 to 1 full turn.
3. Repeat this procedure on opposite side.

Step 6. Attach Top Tube Bar

1. Locate the top tube bar **F**. Position holes in end of top tube bar **F** with holes in upper cross bar **A** as shown in figure 6. Make sure the plastic bumpers **FF** are pointing down (Fig. 6a)!
2. Place one (1) flat washer **L** onto one (1) hex head bolt **J**.
3. Insert bolt **J** through top tube bar **F** and place small spacer **R** on bolt between top tube bar **F** and upper cross bar **A**.
4. Insert bolt through upper cross bar **A**, place one (1) flat washer **L**. Using two 13mm wrenches tighten with one (1) lock nut **M** until all the parts can not move freely. Then loosen the nut by 1/8 to 1/4 turn. **Note:** Do not over-tighten lock nut - these parts

Assembly

need to freely rotate for stand to operate properly.

- Repeat this procedure on opposite side.

Step 7. Attach Linkage Bars

- Align hole in upper linkage bar **D** with hole in top tube bar **F** as shown in figure 7.
- Place one (1) flat washer **L** onto one (1) hex head bolt **K**.
- Insert bolt **K** through linkage bar **D** and place small spacer **R** on bolt between top tube bar **F** and linkage bar **D**.

- Insert bolt through top tube bar **F**, place one (1) flat washer. Using two 13mm wrenches tighten with one (1) lock nut **M** until all the parts cannot move freely. Then loosen the nut by 1/8 to 1/4 turn. **Note:** Do not over-tighten lock nut –these parts need to freely rotate for stand to operate properly.

- Repeat this procedure on opposite side.

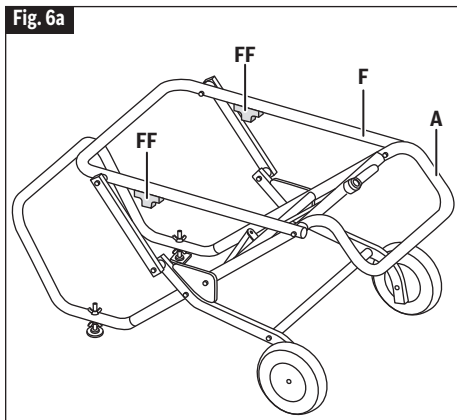
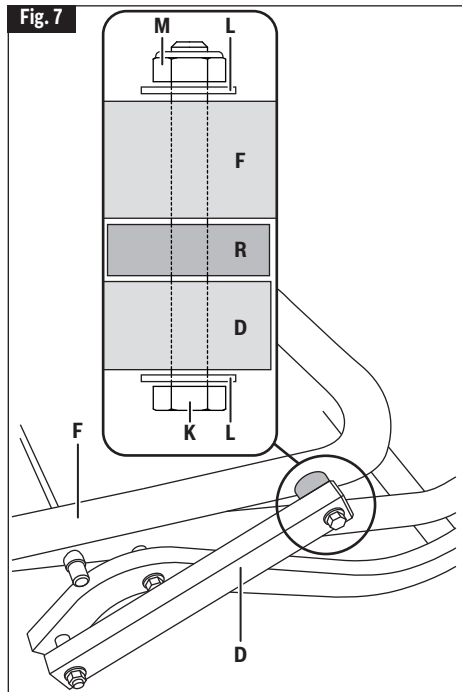
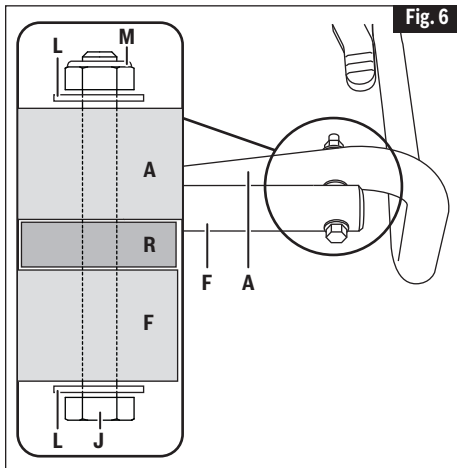

Mounting Table Saw to Stand

For Mounting Bosch 4100 Table Saw to GTA47W Stand

1. Align the saw as shown in figure 8. Note the orientation of the table saw in relation to the square foot **Z**. Insert one (1) hex head bolt **U** through one (1) flat washer **W** and mounting hole in table saw and through top tube bar **F** of the stand.
2. Place one (1) flat washer **W** and securely tighten with one lock nut **V** using two 10mm wrenches.
3. Repeat this procedure on the three remaining mounting holes.

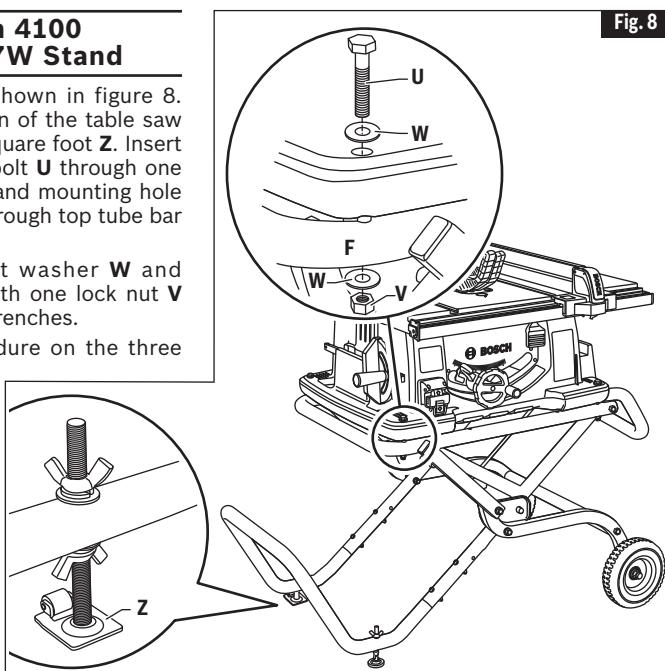

Operating Instructions

Fold Stand Upright

⚠ WARNING Keep fingers clear of hinge points when folding or unfolding the stand.

1. Slightly lift stand by the handle bar (Fig. 9).
2. Rotate release lever down to clear locking pins (Fig. 9).
3. With both hands on the handle, pull up and push forward on the stand (Fig. 10), until it locks in the upright position (Fig. 11).

Lower Stand

1. Rotate the release lever, then pull back on the stand slightly to disengage. Use foot to pull out kick bar **C**, if necessary.
2. With both hands on the handle, pull back and lower the stand until it locks in position.

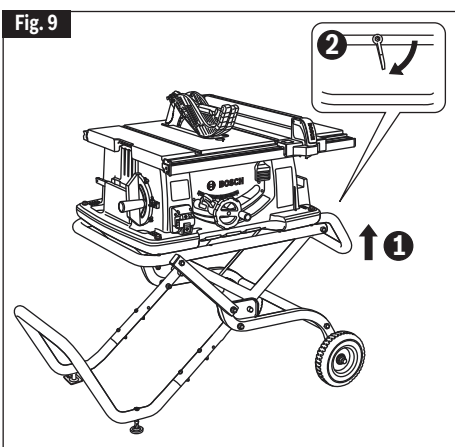

Operating Instructions

Fig. 10

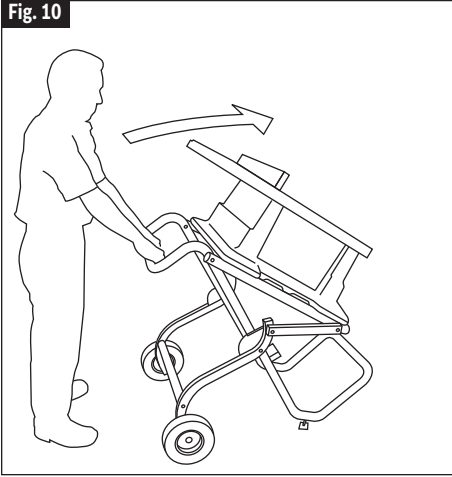
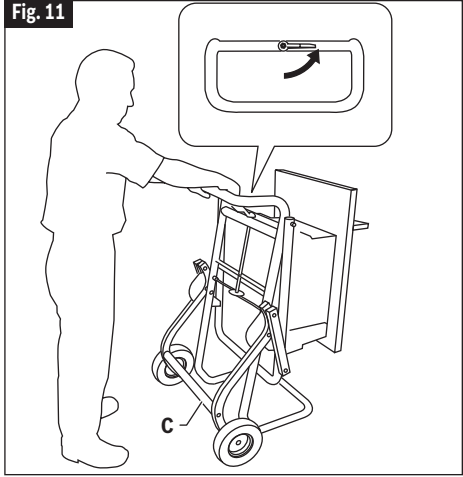

Fig. 11



Lowering Stand to its Lowest Position

Begin with the stand in the locked upright position, as shown above in figure 11.

Firmly grip the handle with both hands and place one foot against the kick bar **C**. Pull back on the handle and lower the stand to the ground, as shown (Fig. 12).

Fig. 12

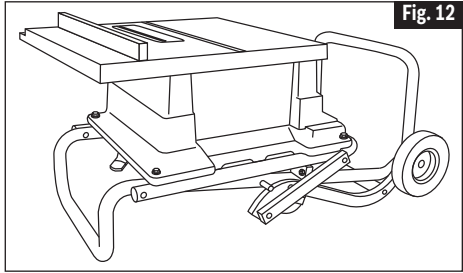

To Level Stand

The stand is equipped with two adjustable feet for leveling the stand.

Adjust the height of the foot (See Fig. 13):

1. Loosen the top wing nut **X**.
2. Adjust the height of the foot by raising or lowering the bottom wing nut **Y**.
3. Retighten both wing nuts securely once the stand is level.

Fig. 13

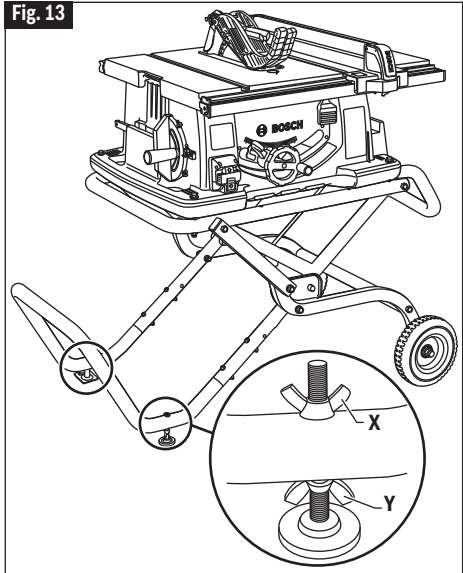

Maintenance

Periodically check that all fasteners are attached and adjusted according to the assembly instructions included in this manual.

Tool Lubrication

Your Bosch tool has been properly lubricated and is ready for use.

Service

⚠ WARNING NO USER SERVICE-ABLE PARTS. We recommend that all tool service be performed by a Bosch Factory Service Center or Authorized Bosch Service Station.